

**T.C.  
ISTANBUL GEDİK UNIVERSITY  
INSTITUTE OF GRADUATE STUDIES**



**THE PERFORMANCE STUDY OF MAGNETIC LEVITATION (MAGLEV)  
FOR SHIPPING AND PASSENGER'S VEHICLE**

**MASTER'S THESIS**

**Youssef NABELSI**

**Engineering Management Master in English Program**

**JULY 2021**

**T.C.  
ISTANBUL GEDİK UNIVERSITY  
INSTITUTE OF GRADUATE STUDIES**



**THE PERFORMANCE STUDY OF MAGNETIC LEVITATION (MAGLEV)  
FOR SHIPPING AND PASSENGER'S VEHICLE**

**MASTER'S THESIS**

**Youssef NABELSI  
(191281035)**

**Engineering Management Master in English Program**

**Thesis Advisor: Prof. Dr. Feriha KUYUMCU**

**JULY 2021**



**T.C.**  
**İSTANBUL GEDİK ÜNİVERSİTESİ**  
**LİSANSÜSTÜ EĞİTİM ENSTİTÜSÜ MÜDÜRLÜĞÜ**

**Yüksek Lisans Tez Onay Belgesi**

Enstitümüz, Engineering Management Department İngilizce Tezli Yüksek Lisans Programı 191281035 numaralı öğrencisi Youssef NABELSI'nin "The Performance Study of Magnetic Levitation (Maglev) For Shipping and Passenger's Vehicle" adlı tez çalışması Enstitümüz Yönetim Kurulunun 13.07.2021 tarihinde oluşturulan jüri tarafından *Oy Birliği* ile Yüksek Lisans tezi olarak *Kabul* edilmiştir.

**Öğretim Üyesi Adı Soyadı**

**Tez Savunma Tarihi:** 13/07/2021

- 1) Tez Danışmanı:** Prof. Dr. Feriha KUYUMCU
- 2) Jüri Üyesi:** Prof. Dr. Uğur ÇELTEKLİGİL
- 3) Jüri Üyesi:** Dr. Öğr. Üyesi Redvan GHASEMLOUNIA

## **DECLARATION**

I, Youssef NABELSI, do hereby declare that this thesis titled as “The Reality of Solid Waste Management in Iraq And Ways of Development the Reality of Solid Waste Management in Iraq And Ways of Development” is original work done by me for the award of the masters degree in the faculty of Engineering Management. I also declare that this thesis or any part of it has not been submitted and presented for any other degree or research paper in any other university or institution. (03/07/2021)

Youssef NABELSI

## **PREFACE**

In the realization of this study, from my background in electrical engineering, the knowledge I gained from studying engineering management and my interest in economics I focused on transportation systems which is the main artery of any country and for Turkey as well. My prof. Dr. Feriha Erfan KUYUMCU was the reason this research is done, she shared her valuable information with me, spared her precious time whenever I consulted her, I would like to thank my professor for everything.

I would like to also thank my other professors for equipping me with the knowledge that will make me a voice and a changer for a better future, and my professors in my ex-university LIU in Lebanon. To my amazing mother thank you for every step I take and you were next to me and always supporting me to become a better person in this life.

July 2021

Youssef NABELSI

---

## TABLE OF CONTENT

	<u>Page</u>
<b>PREFACE</b> .....	<b>iv</b>
<b>TABLE OF CONTENT</b> .....	<b>v</b>
<b>ABBREVIATIONS</b> .....	<b>vii</b>
<b>LIST OF TABLES</b> .....	<b>viii</b>
<b>LIST OF FIGURES</b> .....	<b>ix</b>
<b>ABSTRACT</b> .....	<b>x</b>
<b>ÖZET</b> .....	<b>xi</b>
<b>1. INTRODUCTION</b> .....	<b>1</b>
1.1 Introduction to Maglev.....	1
1.2 Objective.....	2
1.2.1 Research Objective.....	2
1.3 Literature Review.....	2
1.4 Scope of project.....	3
1.5 Outline of Thesis.....	3
<b>2. METHODOLOGY</b> .....	<b>6</b>
2.1 Overview Maglev System.....	6
2.1.1 Speed of maglev trains.....	10
2.1.2 Maintenance.....	10
2.1.3 Energy.....	10
2.1.4 Maglev safety.....	10
2.1.5 Effect of maglev on the environment.....	11
2.1.6 System capacity.....	11
2.2 Hardware Development.....	12
2.2.1 Track Modelling.....	14
2.2.2 Shipments and passenger's maglev vehicle design.....	17
2.3 Controlling System.....	18
<b>3. RESULT AND DISCUSSION</b> .....	<b>20</b>
3.1 Introduction.....	20
3.2 Analysis.....	21
3.2.1 Survey analysis.....	21
3.2.2 Controlling system (magnetic levitation).....	23
3.2.3 Maglev system model.....	24
3.3 Control system design.....	26
3.3.1 LQR controller (Linear quadratic regulator).....	26
3.3.2 PID controller.....	27
3.3.3 Lead compensation.....	27
3.3.4 Maglev motor-Electric Synchronous linear motor.....	28
3.3.5 Studying case from Istanbul to Ankara including system cost & capacity.....	31
3.4 Spreadsheet Cost.....	32
<b>4. CONCLUSION</b> .....	<b>46</b>
4.1 Returning of the Cost.....	47

4.2 Future Profits & Recommendation.....	48
<b>REFERENCES.....</b>	<b>49</b>
<b>RESUME.....</b>	<b>54</b>

## ABBREVIATIONS

<b>ATC</b>	: Automatic Train Central System
<b>DC</b>	: Direct current
<b>DOF</b>	: Degrees of Freedom
<b>EDS</b>	: Electrodynamic suspension
<b>EMS</b>	: Electromagnetic suspension
<b>GDP</b>	: Gross domestic product
<b>K</b>	: kelvin
<b>KE</b>	: kinetic Energy
<b>Kg</b>	: Kilogram
<b>Km</b>	: Kilo meter
<b>L</b>	: Inductors
<b>LQR</b>	: linear–quadratic–Gaussian
<b>LSM</b>	: Linear Synchronous motor
<b>mAh</b>	: milliamp Hour
<b>MFD</b>	: Multifunction Display
<b>mm</b>	: Millimeter
<b>NbTi</b>	: Niobium Titanium
<b>N-N</b>	: North- North
<b>PID</b>	: Proportional, Integral, Derivative
<b>PM</b>	: Permanent magnet
<b>PPP</b>	: Purchasing power parity
<b>R</b>	: Resistors
<b>RL</b>	: Resistors and Inductors
<b>SC</b>	: Superconductor
<b>S-S</b>	: South-South
<b>VDC</b>	: volts of direct current
<b>YHT</b>	: Yüksek Hızlı Tren
<b>Ω</b>	: Ohm



## LIST OF TABLES

	<b><u>Page</u></b>
<b>Table 3.1:</b> Forecasting Service Frequency Changes .....	43
<b>Table 3.2:</b> Forecasting Service Frequency Changes .....	44

## LIST OF FIGURES

	<u>Page</u>
<b>Figure 2.1:</b> Transrapid 01 it Was an Indoor-Only Model Tested On a 6-Meter Long Track With A Top Speed of 48 km/h.....	6
<b>Figure 2.2:</b> Transrapid 09 the Last Version of Transrapid Project With a Top Speed of 505 km/h. ....	7
<b>Figure 2.3:</b> Electromagnetic Suspension (EMS).....	7
<b>Figure 2.4:</b> L0 Series Shinkansen the fastest maglev with speed up to 603 km/h.....	8
<b>Figure 2.5:</b> Electrodynamic Suspension (EDS).....	9
<b>Figure 2.6:</b> Design of the SC Maglev guide way.....	15
<b>Figure 2.7:</b> Arrangements of the Null-Flux Levitation Coil Consisting of Null-Flux Connected Coils in the Sidewall of the EDS Track. ....	15
<b>Figure 2.8:</b> Developing an Efficient Model for Analyzing a Null-Flux EDS Device: (a) Simplifying a Levitation Coil to the Integrated N Turns of the Rectangle, (b) The Design in Planes L and R Where the Coils Are Located. ....	17
<b>Figure 2.9:</b> SC Maglev System Concept.....	18
<b>Figure 2.10:</b> This Graph Shows the Running Curve of the SC Maglev.....	19
<b>Figure 3.1:</b> Percentage of the Transportation System That Used the Most .....	22
<b>Figure 3.2:</b> Percentage of People that Prefer to Metro with Other Transportation Systems.....	22
<b>Figure 3.3:</b> Body Diagram of Magnetic Levitation System.....	25
<b>Figure 3.4:</b> Electromagnetic levitation system model.....	26
<b>Figure 3.5:</b> Block Diagram of PID Controller .....	27
<b>Figure 3.6:</b> Superconducting Coil .....	30
<b>Figure 3.7:</b> Istanbul-Ankara corridor, hızlı tren railway.....	31
<b>Figure 3.8:</b> The Overall Travel Time Structure .....	37
<b>Figure 3.9:</b> Maglev road map.....	42
<b>Figure 3.10:</b> Cities SC Maglev Train will pass through .....	43
<b>Figure 3.11:</b> Final Istanbul- Ankara Design Concept.....	45

## **THE PERFORMANCE STUDY OF MAGNETIC LEVITATION (MAGLEV) FOR SHIPPING AND PASSENGER'S VEHICLE**

### **ABSTRACT**

The growth in the population is related to growth in economics, moreover the main propitious is the under structure of the city and the main encouragement is the transportation systems since it can improve the growth of the economy and by moving people and products move faster. Focusing on Turkey, more than 30% of the population leave between Istanbul and Ankara in the same time the growth of the Turkish economy is increasing by 4.8% as a yearly growth.

This Research is a performance study of implementing the fastest transportation system available nowadays which is magnetic Levitation known as MAGLEV between two of the biggest cities of Turkey Istanbul and Ankara with a convertible system that allows the MAGLEV's vehicle to change from a passenger vehicle to products shipping vehicle and this convertible method will take less than 15 minutes. The speed of this system is more than 600 km/h, it can travel from Istanbul to Ankara in less than 60 minutes by the technology of magnetic levitation, the train doesn't have any wheels the vehicle will levitate not more than 10 cm and will create zero friction the train is flying over the guide way by the use of magnets or superconductors.

**Keywords:** *Transportation, Economy, Magnetic Levitation, Electrodynamics Suspension, shipping, Population.*

## NAKLİYE VE YOLCU ARACI İÇİN MANYETİK LEVİTASYONUNUN (MAGLEV) PERFORMANS ÇALIŞMASI

### ÖZET

Nüfustaki büyüme, ekonomideki büyüme ile ilgilidir, dahası, şehrin alt yapısı en elverişli olanıdır ve ana teşvik, ekonominin büyümesini iyileştirebileceği ve insanları ve ürünleri hareket ettirerek daha hızlı hareket edebileceği için ulaşım sistemleridir. Türkiye'ye odaklanan nüfusun %30'dan fazlası İstanbul ve Ankara arasında ayrılırken, aynı zamanda Türkiye ekonomisinin büyümesi yıllık büyüme olarak %4,8 artıyor.

Bu Araştırma, Türkiye'nin en büyük iki şehri İstanbul ve Ankara arasında, günümüzde mevcut olan en hızlı ulaşım sistemi olan MAGLEV olarak bilinen manyetik Levitasyonunun, MAGLEV'in aracının binek araçtan ürün taşımacılığına geçmesine olanak sağlayan dönüştürülebilir bir sistemle uygulanmasına yönelik bir performans çalışmasıdır. araç ve bu dönüştürülebilir yöntem 15 dakikadan az sürecektir. Bu sistemin hızı 600 km/s'den fazladır, manyetik levitasyon teknolojisi ile İstanbul'dan Ankara'ya 60 dakikadan daha kısa sürede gidebilir, trenin tekerleği yoktur, araç 10 cm'den fazla havaya kalkamaz ve Mıknatıslar veya süper iletkenler kullanarak trenin kılavuz yolu üzerinde uçtuğu sıfır sürtünme yaratacaktır.

**Anahtar Kelimeler:** *Ulaşım, Ekonomi, Manyetik Levitasyon, Elektrodinamik Süspansiyon, nakliye, nüfus*

## **1. INTRODUCTION**

### **1.1 Introduction to Maglev**

When talking about technological development transportation systems is the first thing every city focus to improve to become a development city. The oldest known system of human and animal rail transit originates from the 6th century B.C., but contemporary rail transit is reserved for George Stephenson and his son's steam engines at Merthyr Tydfil. It all began in the United Kingdom. The locomotive that was done by George Stephenson was the first steam locomotive constructed to carry people on public rail, and the world's first intercity railway was built entirely with steam engines. It ran from Liverpool to Manchester and was completed in 1830. One of the most important aspects of the Industrial Revolution is this. The utilization of a freight rail system cut transportation costs while also minimizing property damage. One of the most important technological breakthroughs of the nineteenth century was the invention and development of British railways. Railway electrification systems were developed in the 1880s, which led to the electrification of tramways and rapid transit systems. In most nations, non-electrified railways saw their steam locomotives replaced by diesel-electric locomotives starting in the 1940s, while electrified high-speed railway systems were implemented in Japan and later in other nations start to developed in the 1960s. Other kinds of guided ground transportation, such as maglev, fall beyond the typical railway classification.

Maglev railroads are cars and suspended rails that are propelled by electromagnetic force. Magnetic materials and systems can be attracted to or crushed by forces that are proportional to the magnetic field and the magnet's area. Levitation, for example, is a dipole magnet that is put in the magnetic field of another dipole magnet that has the same poles and repels each other. The railway car in a linear motor has only one moving element. The train goes down the pilot track with the help of magnets, which manage the train's stability and speed. For movement and flight, no moving parts are necessary. This is in sharp contrast to the various electrical boxes found in each car, each of which might store dozens of pieces. As a result, ferromagnetic trains are

significantly quieter and smoother than standard trains, as well as being significantly quicker and carrying more passengers.

## **1.2 Objective**

The aims from this study to understand the Maglev systems available and which one of them is better to be used for the Istanbul Ankara Maglev to understand the impact of the high-speed transport system between the two urban areas, the importance of fast shipping and it can help in increasing the economies and to calculate the global budget of the system.

### **1.2.1 Research Objective**

- Explain the maglev system
- Understand the difference between EDS and EMS.
- Choosing the right system for this project.
- To illustrate the imports of this system and how it can improve the Turkish economics.
- Overview of the passenger and shipping system of this study.
- Knowing when the cost will be returned.
- Future recommendation.

## **1.3 Literature Review**

The research gives an understanding of the maglev systems in literature and discusses the difference between the two systems EDS which created by the Japanese and EMS which is created by Germans, describing the Maglev systems that can be use and why for applying Istanbul-Ankara maglev train. Design of a convertible system that is responsible to change the train from passengers situation to shipping situation and the cabin will be prepare before changing. The research then moves on looking at the increasing numbers of the population and the increasing of the Turkish economics that's going to be one of the top 5 economies in 2030 and the transportation Maglev system how it's going to make a big change in increasing the economies and how it can improve the infrastructure of the biggest two Ankara and Istanbul. Survey is done to know which transportation system is preferred by the people who use transportation system in Istanbul and Ankara, and if is system will be

available how make will use it. To conclude the literature, the whole project will cost, return the cost, and the future recommendation.

#### **1.4 Scope of project**

Maglev technology is very expensive, it's going to cost billions of dollars for building a new railway and it will take more than 5 years to build. Why investment cost of the Maglev Technology system is very high, this research focuses on why Maglev technology should be preferred and what it will improve.

Explaining the purpose of using Maglev technology, understating the two types of Maglevs, how the system works, Germans and japans are the only countries that proved Maglev system, the research explores the EMS and EDS of Maglev system. Which system of EMS or EDS is better to be used in this project, the chapter further explains the speed, maintenance, energy, safety and system capacity.

The research will give a design aspects for the hardware and software of the tracking modeling, the system planning design will include the shipping and passenger's maglev vehicle design. The controlling system of the Maglev will be explained in using with the Matlab software.

#### **1.5 Outline of Thesis**

The lag in transportation because of the long distances between cities, the increase in the population in Istanbul, the big quantity of shipments that shipped every day between Istanbul and Ankara, the need for a fast transporting system that can move passengers and products in less than 1 hour.

This project is going to improve the transportation system in the whole country by decreasing the time of traveling from Istanbul to Ankara for passengers and for delivering products. Will open new cities in the way where the railway will be installed. Increase the manufacturing suppliers and the products that will be exported between cities or outside the country and this will affect the economics by increasing it.

Using the SC Maglev system that is the fastest transportation system, applying innovation in this system to be able to move both passengers and shipments at the

railway in less than 1 hour. This system will let people live outside the center of the cities and even outside the city itself.

The case study of SC Maglev from Istanbul to Ankara uses the calculation of control systems, crane design systems, operator costs, operating costs and environmental costs to determine the electrical design of the levitation system for this project. In addition, operating costs are related to the costs of building and maintaining the infrastructure, as well as the costs associated with the acquisition, operation and maintenance of SC Maglev vehicles. The usage fee varies according to travel time, such as entry / exit time, waiting time and time in the car. The time value is taken into account to obtain the calculated usage cost. External costs include air pollution, noise pollution, accidents and climate change per 1 km of passengers.

### **Introduction**

The term "maglev" refers to a technique that lifts a vehicle by using electromagnetic forces between ground coils and superconducting magnets on board. Maglev transit is another kind of transport that utilizes electromagnetic force to suspend guides and push cars. Maglev refers to both cars and the railway system, while levitation is a propulsion method that uses magnets rather than wheels to move vehicles. Maglev is a cutting-edge technology that uses a magnetic field to create a barrier between the guideway and the vehicle.

Maglev vehicles do not have wheels, gearboxes, or axles, instead depending on magnetic levitation for navigation and propulsion. Additionally, these vehicles travel through magnetic fields created by the vehicle and its guiding path. In this scenario, an electronic control system will maintain the vehicle levitate at a contact distance of 10 mm from its directing path (Lee Kim, 2006). Maglev trains go more smoothly, silently, and with less friction than wheeled mass transport systems, and need only a tiny fraction of the total energy consumed for levitation, with the remainder utilized to overcome air resistance. Electromagnets on the train's underbelly attract it to the ferromagnetic stators (current) on the track and raise it, while magnets on the sides hold it stationary. The computer automatically changes the current to maintain the train within one centimeter of the track. Catenary is the preferred technology for high-speed Maglev.



However, if contactless energy transfer (e.g. linear generator, inductive power transfer, transformer action, and gas turbine generator) is contemplated for low-speed Maglev with a DC voltage of 1500 VDC, catenary is the preferred technology (Lin. Shen, 2018). Flux harmonics produced in the wires put in each motor pole enable the linear generator to be used at high-speed Maglev in this situation.

## 2. METHODOLOGY

### 2.1 Overview Maglev System

In the early 20<sup>th</sup> century Emile Bachelet and Robert Goddard to present a vehicle that would float by magnets. First in the 1930's German researcher called Hermann Kemper was given a patent he gave us the first concept of a magnetic levitating train by using Electromagnetic Suspension (EMS), but the first manifest for the idea came at the end of the 1960s by Transrapid 01 it was an indoor model tested on a 6-meter track. It has the box shape of this early model because it was only for testing purposes, the next versions had more aerodynamic lines. Transrapid project continued till 2007 by implementing 10 versions from maglev it was improving from version, there is one called SMT it was also known as Transrapid 08 that installed in China that connect Shanghai Pudong International Airport with Shanghai city it was the first and the only system that is working till nowadays with a speed of 480 km/h. Transrapid 09 in the last version of this project they focused more on automation and the design speed was 505 km/h (Min. kwon, 2017).



**Figure 2.1:** Transrapid 01 it Was an Indoor-Only Model Tested On a 6-Meter Long Track With A Top Speed of 48 km/h

**Source:** [maglev.net/transrapid-design-history](http://maglev.net/transrapid-design-history)



**Figure 2.2:** Transrapid 09 the Last Version of Transrapid Project With a Top Speed of 505 km/h.

**Source:** [theloadstar.com/maglev-trains](http://theloadstar.com/maglev-trains)

Japan followed Germany by testing two series of their own design with different technology in maglev's called Electrodynamics Suspension (EDS), one called ML-500 and the second one called superconductor maglev (SC Maglev), Japan prototype was able to reach 480 km/h. Japan didn't stop here continued developing in magnetic levitation technology into the 1990's they tested new series called the MLX, which broke the speed of 560 km/h in 2003, and they are constructing the Maglev Shinkansen project that uses superconductors started in 1990 and officially debuted in 1997 because of the bubble economy, but the project it's catapulted back into the spotlight in 2007 and it will be finished in 2025 between Tokyo and Nagoya it will slash the trip to 40 minutes instead of the current time of a 90 minutes (6).

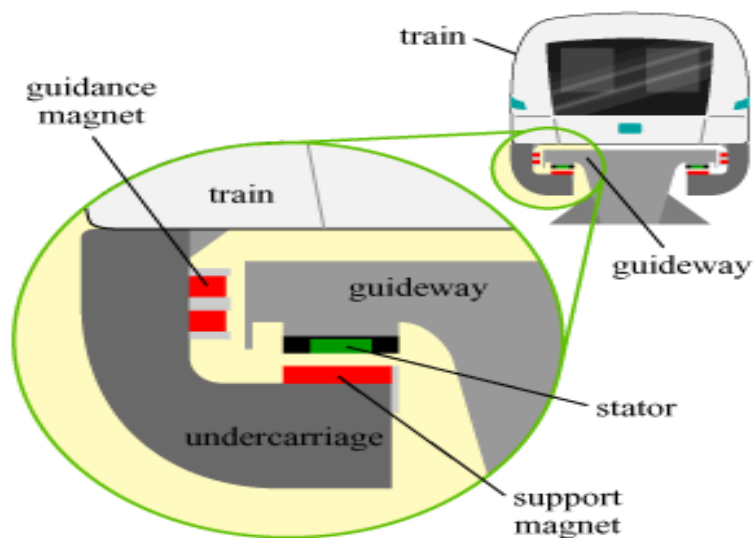

**Figure 2.3:** Electromagnetic Suspension (EMS)

**Source:** [britannica.com/technology/maglev-train](http://britannica.com/technology/maglev-train)

- Electromagnetic Suspension (EMS): Is the vehicle's bottom encircled by the track in the form of a c-shaped arm. Electromagnets are placed in the section of the arm that is not in contact with the track. The electromagnets are drawn to the track and maintain the vehicle's hovering position. By varying the current supplied to electromagnets, the magnetic field's intensity is continuously changed. Aproximately 15 millimeters separate the car from the track. (J.Berg, 2012).

Advantages:

- Low magnetic fields inside and outside the vehicle
- Commercially available
- No secondary propulsion system needed

Disadvantages:

- The system must be monitored externally to ensure that the space between the track and the train is maintained.
- Vibrations may arise as a result of instability or external monitoring.



**Figure 2.4:** L0 Series Shinkansen the fastest maglev with speed up to 603 km/h

**Source:** [scmaglev.jr-central-global.com/gallery](http://scmaglev.jr-central-global.com/gallery)

Electrodynamics Suspension (EDS): Currents in the guide path are caused by magnets aboard the train. These currents produce magnetic fields that interact with the magnets' initial field. The repulsive force between the two fields aids in levitation. The train's magnets are either electromagnets or a permanent magnet

system. The benefit of EDS systems is that they are stable, requiring no feedback control to operate. Superconductors are materials that conduct electricity without resistance. This technology can carry a current continuously without wasting energy, but superconductors require specific conduction to operate at temperatures above 77k, which is around  $-196\text{ }^{\circ}\text{C}$  (J.Yao, 2014). In September 2020, a study revealed a new mechanism of superconductivity which is SrRuO<sub>4</sub>, known as g-wave, room-temperature superconductor at  $15^{\circ}\text{C}$  was reported in a carbonaceous sulphur hydride at very high pressure 267 GPa triggered into crystallization via green laser (Z. Ding, 2016). This new study has the potential to make the SC Maglev more efficient and practical to utilize.

Advantages:

- No power required to activating the magnets
- Can levitate at low speed (5 km/h)
- Lower Cost

Disadvantages:

- Wheels needed at slow speed
- More expensive than EMS

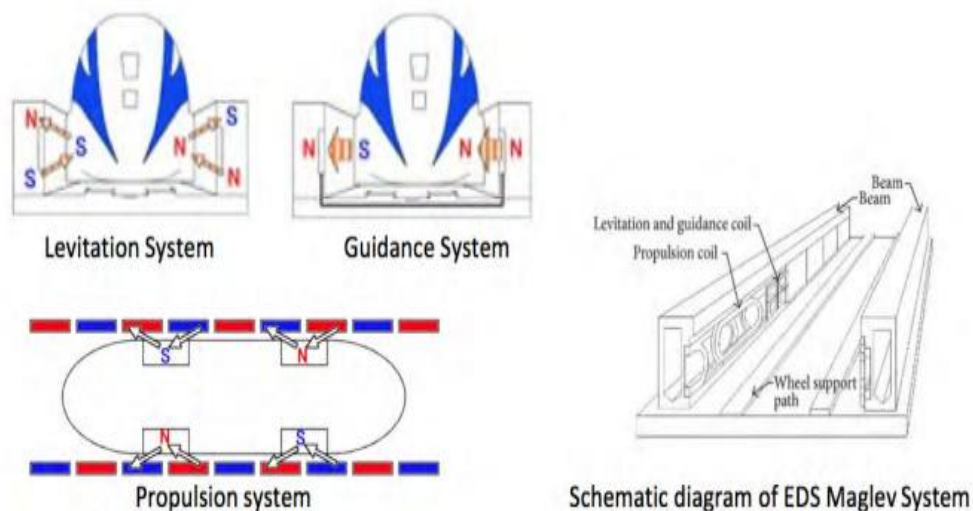

**Figure 2.5:** Electrodynamic Suspension (EDS)

**Source:** Vacuum tube high temperature superconducting maglev train

### **2.1.1 Speed of maglev trains**

The most important feature in Maglev technology is the high speed, magnetic levitation since it started the main idea from it is to reach high speeds by decreasing the friction, in fact the inventor of Maglev Eric Laith waite launched the first commercial Maglev train in 1984 in Birmingham with a speed of only 24 km/h and the program was closed in 1995 because they faced problems in design and reliability but it was just the beginning of the Maglevs, In 1987, the second Maglev train in the world, and the first by German technology, was built with a speed of 420 km/h utilizing EMS technology, and we can witness EMS in Shanghai Maglev train with a speed of 500 km/h. SC Maglev, the world's fastest maglev train on earth, achieved a speed of 603 km/h in 2015 by L0 (L-zero) and holds the Guinness record for the world's fastest maglev train on earth utilizing Japanese technology EDS (C. Chung, 2012 ).

### **2.1.2 Maintenance**

Guide ways can last for at least 50 years with a minimal maintenance In Electromagnetic Suspension (EMS) since there is no mechanical contact and wear parts that need maintenance this not that much, in the other hand Electrodynamic Suspension (EDS) need more maintenance because it uses wheels for traveling at low speed. But overall Maglev technology in general doesn't require that maintenance as much as Induct rack systems.

### **2.1.3 Energy**

Maglev system consumes less energy than Induct rack system that consumes 4 mega joules per 80 kg for oil fuel 8.5-kilometers per litter compared to EMS that reaches 480 km/h it consumes 0.4 mega joules per 80 kg compared. For the EDS it can be even less than EMS by 40% by using superconducting magnets allows the SC maglev which uses EDS and 50% less than a commercial airliner (Boeing 777) it can be considered one of the most efficient large scale transit.

### **2.1.4 Maglev safety**

Because system function necessitates the monitoring of vehicle location and speed, the likelihood of collisions and other mishaps might be completely minimized. Elevated structures will eliminate grade crossing issues and limit the likelihood of

things being put on or falling onto the guide way. There are no standards regarding acceptable amounts of magnetic field exposure for travelers. However, if necessary for passenger and crew safety, magnetic fields created by the levitation and propulsion magnets may be decreased using magnet design and field shielding techniques. Because they go down fast with distance and are intermittent in comparison to any roadside reference point, fields outside the system should have minimal safety or environmental relevance.

In the case of power outage, the EDS would come to a halt in the same way it would in regular operation. The operation of the on-board magnets is independent of a power source. The natural braking action is provided by the electromagnetic drag force created by the magnets and guiding path till the vehicle settles on its wheels if on-board power fails, the EMS maglev vehicle is equipped with skids that touch and slide on the guide rails.

### **2.1.5 Effect of maglev on the environment**

With a no-contacting maglev system, noise and track-side vibration, both of which have been recognized as major issues with Japanese bullet trains, should be substantially decreased. Air pollution emissions would be confined to the central generating plant, where they would be relatively easy to control. (This is in contrast to uncontrolled aircraft emissions, which are concentrated around airports in major cities.) Electromagnetic interference caused by sparking between electrical connections on ultra-high-speed trains would be avoided with maglev systems.

### **2.1.6 System capacity**

The capacity of a maglev line is influenced by the weight per car, the number of cars per vehicle or train, and the time interval between vehicles. A steady-state capacity of 720 tons/h each direction could be reached using single-car cars, a 12,000 kg/h vehicle, and 1 minute headways. If paired vehicles were used, the system's capacity would be doubled. When compared to expressway traffic, the peak capacity of a single traffic lane under ideal circumstances is 700 vehicles per hour traveling at 100 km/h, according to the Transportation Research Board's highway capacity handbook. Each lane has a capacity of 100 tons per hour if the average vehicle occupancy rate for intercity travel is 1.8. As a consequence, a single-car maglev system with a capacity of more than seven highway lanes is possible. Furthermore, whereas

highway cars move at 100 kilometers per hour, the maglev vehicle speeds at 500 kilometers per hour. A system of 50-ton train, with a fast maglev vehicle with electromagnetic suspension (EMS) can lift an extra 20 tons for a total of 80 tons (J.S. Lee, 2012).

When comparing maglev capacity to airplane runway capacity, a single runway can handle around 40 take-offs or landings per hour under optimum conditions. Assuming a 12 ton/short-haul aircraft, a capacity of 480 tons/h is obtained. Thus, for a big hub airport, a maglev network of four to five lines would be comparable to six to eight all-weather runways.

## **2.2 Hardware Development**

According to the comparison between the EMS and EDS, we can analyze that the EDS is better for the shipping maglev project since, from its high speed that can cross over 603 km/h moreover the capacity of the EDS is higher than EMS for shipping it can levitate 70,000 times its own weight (UIC, 2018). In our hardware development part we will study the Electrodynamics suspension system (EDS).

While moving, traditional trains cause friction between the wheels and tracks. The wheels slide when driving too rapidly, therefore the maximum speed is limited. By suspending the train above the track, the maglev bypasses this constraint. The SC Maglev system is free of friction-induced noise since there is no contact between the wheels and rails, or between the contact wires and pantographs. Noise created by the rolling stock's aerodynamics and construction. Environmental laws required the use of barriers and hoods (UIC, 2018). The power feeding method of conventional railroads requires interaction between contact wires and pantographs. High-speed rail performance would increase junction wire vibration and pantograph separation, jeopardizing rolling stock power supply. Inductive power collecting technology uses the concept of electromagnetic induction to provide a reliable, contact-free supply of energy to the superconducting Maglev even at high speeds. Noise from pantographs contacting junction wires is also removed by the technology. To produce a magnetic field, an electrical feeder current is sent to ground coils, and then electromagnetic induction generates an electric current in onboard coils for in-car facilities.



The motor converts energy into rotation using magnetic force. The locomotive must be driven by attractive forces between the north and south poles, as well as repulsive forces between the S-S and N-N poles (Monjo, 2015). A well-known motor mechanism underpins the superconducting Maglev technology. The term "linear motor" refers to the alignment of motors in a straight line. A linear motor is a spinning motor that has been linearly expanded and extended. A permanent magnet is a magnetized material that produces a steady magnetic field.

The 600 km/h superconducting maglev levitates approximately 4 inches above the guiding path. To generate a large magnetic force, a typical conducting magnet needs a lot of electric power, but electrical resistance generates heat, which loses energy (Danby, 2007). An electromagnet needs electric current to respond as a magnet, and the N and S poles may be switched by altering the electric current's direction. The superconducting maglev uses superconducting magnets to generate a high magnetic force, utilizing a phenomenon known as "superconductivity," which occurs when the electrical resistance of certain materials approaches zero at low temperatures, and when an electrical current is applied to a superconducting coil, the current flows virtually indefinitely (U. Hasirci, 2015). Superconducting material is cooled to 452 degrees Fahrenheit below zero, or 4.2 kelvin, in the Superconducting maglev system, using helium liquid and a niobium-titanium alloy. This results in a niobium-titanium alloy coil with even greater magnetic force, as well as semi-permanent electric current feeding and superconducting with little thermal energy loss. The train's superconducting magnets and the guide way's electromagnets interact and repel each other, levitating and propelling the train ahead by 3.9 inches (Birenbaum, 2015). The guide route carries propulsion coils, as well as levitation and guiding coils. The train's superconducting magnets and the guide way's electromagnets interact and repel one another, levitating and propelling the locomotive forward by around 3.9 inches.

Superconducting magnets on rolling stock are set to N and the poles alternate. Electric power is applied to "propulsion" on the guide route to propel the train forward, and their N-pole and S-pole assignments are electronically changed. The frequency of electric current is changed to control the train's speed, and the speed is controlled by switching between N and S poles (Kim DS, 2016).

The Superconducting Maglev is a contactless technology that achieves exceptional acceleration and deceleration by using magnetic force generated between the stock and ground coils and superconducting magnets on rolling. Unlike conventional rail systems that use wheels and tracks, it has no wheel slippage during acceleration and no sliding during deceleration (Long Z, 2011). The blue line on the graph shows the acceleration and deceleration performance of the Superconducting Maglev's series L0 rolling stock (Han HS, 2016). It has the ability to accelerate to 311 mph in a short period of time and stop in about the same time. This demonstrates SC Maglev's better acceleration/deceleration capabilities when compared to other conventional train systems. This exceptional performance enables the train to travel at full speed for a considerable part of its trip, allowing for 603 km/h mass high-speed transportation (UIC, 2018).

Superconducting propels and levitates using "propulsion coils" and "Levitation and Guidance coils." When additional magnets get near to the "Levitation and Guidance coils," they convert become magnets, which is how Maglev works. As superconducting magnets on rolling stock pass by at high speeds, electric current passes through the Levitation and Guidance coils, generating magnetic force and levitating and maintaining the train at a height where the train's weight is stable against the magnetic force. (The height of the levitation is about 3.9 inches.) The Levitation and Guidance coils are utilized to achieve train levitation. It is not essential to provide them access to electricity. (Balikci Ak, 2015)

The train is kept from smashing into the guide way walls by magnetic force, and the guide way's rolling stock travels in the center. Despite the rolling stock tilting to one side, the magnetic force that reacts between superconducting magnets and the Levitation and Guidance coils keeps the train centered in the guide path at all times. The magnetic force keeps the superconducting Maglev from clashing with the guide way walls, ensuring that it runs smoothly.

### **2.2.1 Track Modelling**

As we mentioned before in the Hardware development the Superconducting maglev system has to main parts on the track the Electrodynamics suspension (EDS) for levitation the armature coils of a linear synchronous motor (LSM) eight-figured

levitation coils for propulsion (P. Verges, 2005 ), also superconducting wire liquid helium used for cooling magnets on board using NbTi.

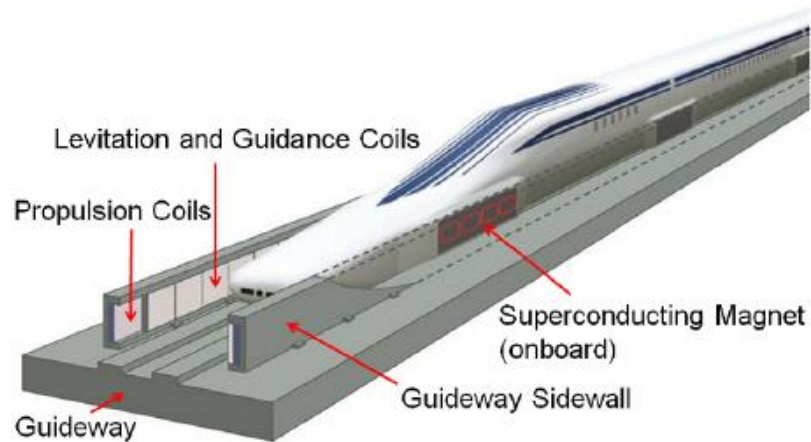

**Figure 2.6:** Design of the SC Maglev guide way

**Source:** Brookhaven National Laboratory, one of the Department of Energy's 17 National Labs

A continuous array of zero flux lift coils consisting of four lift coils in the same x location linked to an empty flux is used in the Electro Dynamic Suspension (EDS) zero flux route. All lifting coils, on the other hand, are electrically isolated in the direction of motion. The primary design of the zero-flow EDS device is a better lift coil form via an iterative process that evaluates the force response to SC Maglev fired by the moving bogie, because the null flux coil is built in much the same manner (Homer, 2003).

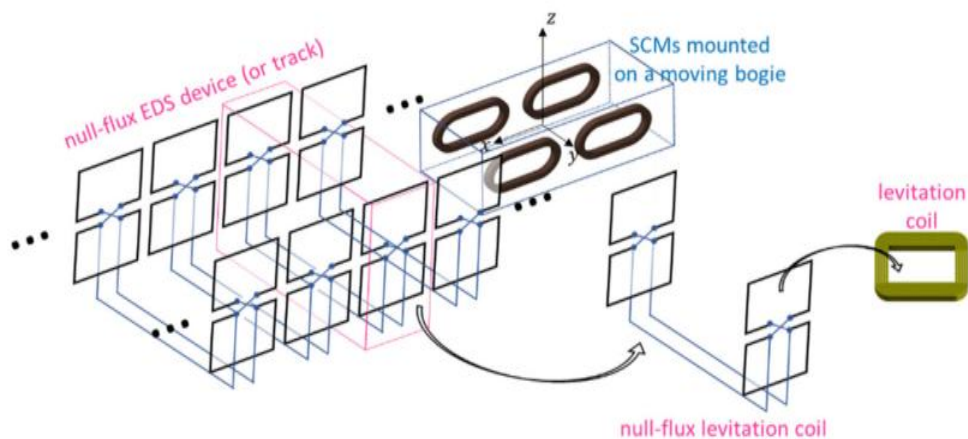

**Figure 2.7:** Arrangements of the Null-Flux Levitation Coil Consisting of Null-Flux Connected Coils in the Sidewall of the EDS Track.

**Source:** Design Model of Null-Flux Coil Electrodynamic Suspension for the Hyperloop

Models of Design Multi-cycle and multi-layer files are often thought to make design analysis easier, however designs are typically created because particular

characteristics must be taken into account when evaluating multiple file designs. It will be limited in scope. The fly coil's cross section is simplified from a dispersed N-turn to a linked N-turn, and the coil form is simplified from a two-dimensional rectangular shape to a two-dimensional rectangular shape using dynamic circuit theory (J. Meins, 1988). If the SCM wire and coil are well spaced relative to the cross section of the coil, this simplification may be used to EDS pathways without flash. A self-induced static multiplier also simplifies the impact of magnetic coupling between neighboring levitation coils. The independent RL equations for the coil may then be used to write the induced current and electromagnetic force in the closed-form solution. The pairing effect is smaller than the facing coils since the coils are placed side by side, and the  $L_s$  self-inductance may prevail. Furthermore, since the SCM (WJ. Mayer, 1988), which is made up of a pair of N and S electrodes, produces a periodic MFD in the direction of movement, the EMF generated in the coil by the moving SCM is likewise periodic. In this instance, utilizing self-induction without coupling effects (UZUKA, 2011), the performance of various coil designs can be effectively evaluated and compared, and the effective inductance can be calculated. The discrete RL equation should be solved using the  $L_e$  equation multiplied by the appropriate coupling effect KE. Able to obtain precise results.

$$L_e = k_e L_s \tag{2.1}$$

The simplified rectangular coil is respectively placed in two layers, level L and R, as shown in Fig.7. Next, the coil design is to find a simplified rectangular file shape for optimum performance. In addition, the analytical model shown below uses L- and R-plane SC Maglev magnetic fields only where fly coils are located to provide faster calculations. Inductive EMF models, current models, and zero flow forces will be discussed later on Zero Flow EDS devices.

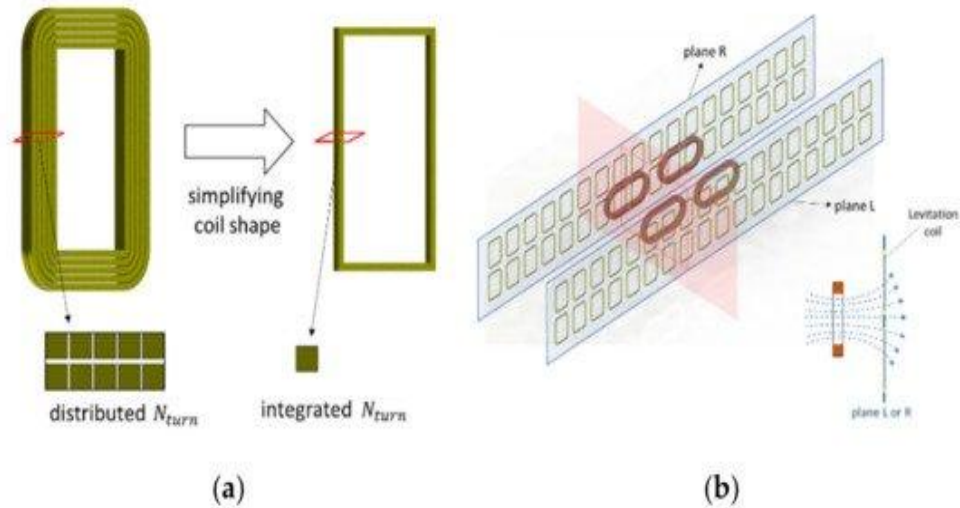

**Figure 2.8:** Developing an Efficient Model for Analyzing a Null-Flux EDS Device: (a) Simplifying a Levitation Coil to the Integrated N Turns of the Rectangle, (b) The Design in Planes L and R Where the Coils Are Located.

**Source:** Hyperloop and Associated Technologies

The simplified rectangular file is placed on two consecutive layers in the L and R planes, as shown in Figure 2.8. Next, in file design, find a simplified rectangular file shape for optimal performance. In addition, the analytical model described below uses the SCM magnetic field only on the L and R planes where the levitation coils are located, providing faster calculations. The inductive EMF model, the current model, and the zero-flow intensity of flux-free EDS will be discussed later.

### 2.2.2 Shipments and passenger's maglev vehicle design

As mentioned before this system will move both passengers and shipments. Throw it unique design which have a fixed body on the guide way and a removable shipment container and passengers cabin there is a machine system that can change the shipment container and passengers cabin by switch between them using hydraulic barrier, this operation will not take more than 15 minutes, for the passengers cabin the cabin will open after installing it on the body of the train while the shipment container will be already prepared before installing it with the body.

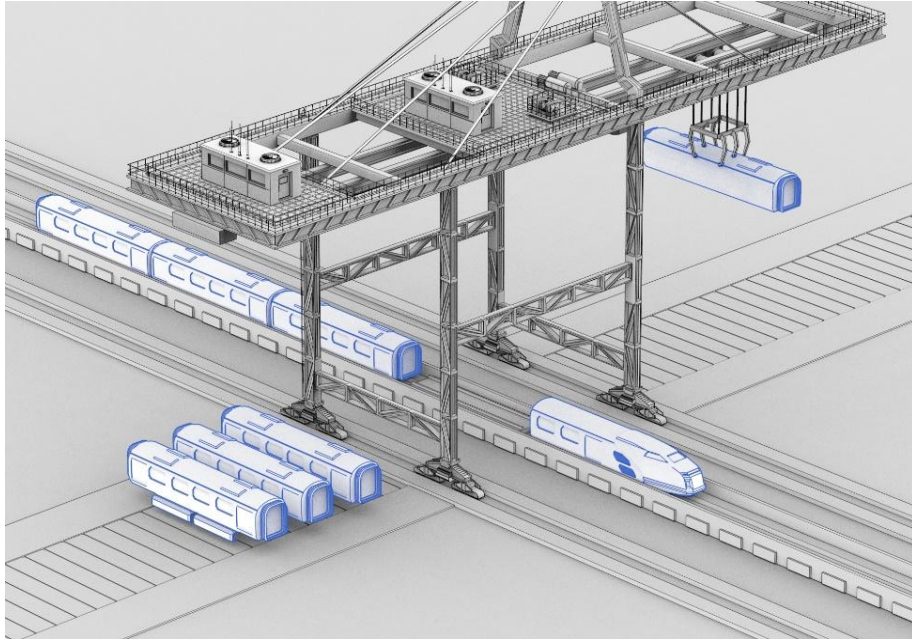

**Figure 2.9: SC Maglev System Concept**

This concept above shows the SC Maglev system with the lifter system, the SC Maglev system which is the train in this concept have a fixed body with a convertible cabins, the system that's changing between the passengers cabin and the shipment containers is the lifter system, there will be two lifters the first one will be taking place in Istanbul's station and the second one will take place in Ankara's station. The role of this lifter as shown in the concept is to change the containers or the cabin according to need. There is two way conveyor one on the right and other one on the left, the right one is for the container shipments and the left one for the passenger's cabin, this operation will take place after the station when all the passengers left the cabin.

### **2.3 Controlling System**

The superconducting Maglev, which has a maximum speed of 6.3 km/h, inherits the Tokaido shinkasento's safety philosophy and technology, which guarantee operational safety (29). To prevent trains from colliding or running at excessive speeds, the Tokaido shinkansen employs the (ATC) Automatic Train Control system. The ATC receives signets that include data such as the train's distance from the train ahead of it through railway lines. The ATC constantly shows the maximum speed to the driver based on the signals. The train driver adjusts the accelerator "notch" and brake to regulate the train's speed based on the "signal speed" shown in the driver's

cabin in order to go past or halt at the next station at the time indicated in the schedule (LN.Tuelea, 2018). If the actual speed is faster than the signal speed displayed, the brake is applied automatically and released when the signal speed is achieved. When stopping at a station, the train decelerates to 19 mph automatically and then the driver manually applies the brake to safely bring the train to stop. The superconducting maglev does not need to have a driver onboard because it uses the automatic train operation system in which the operation is controlled from ground facilities (NC.Shieh, 2014). The superconducting maglev operates punctually by following the running curve prepared in advance at the control center at the ground level. The running curve, electricity is fed from a substation to the propulsion coils on the ground s Electricity is supplied from a substation to the propulsion coils on the ground side to automatically drive the train based on the operating curve.

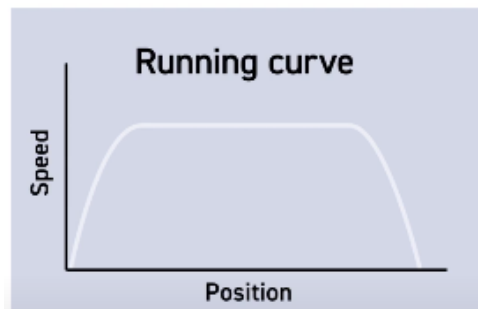

**Figure 2.10:** This Graph Shows the Running Curve of the SC Maglev

The volume and frequency of electric current supplied to the propulsion coils on the right and left sides of the train may be changed to regulate the train's acceleration and deceleration (Otkum, 2017). As a result, the system manages each train from start to finish according to its operating curve, while computers in the control center continuously monitor the train's location, speed, and rolling stock characteristics. The safety control system, which is entirely autonomous from the automated train operating system, is triggered instantly in the rare event that a train exceeds the speed specified in its running curve. This is a system comparable to the Tokaido shinkansen's "ATC" for guaranteeing operating safety. The superconducting Maglev ensures operating safety not only by adopting the safety philosophy and technology of the Tokaido Shinkansen, but also by using its unique systems of enhanced precision and dependability (Otkum, 2017)

### **3. RESULT AND DISCUSSION**

#### **3.1 Introduction**

As maintained in chapter 2 the comparison between the two maglev systems EDS and EMS, EMS was leading technology from 20 years ago so it was the building of Shanghai maglev train that connects shanghai pudding international airport with the center of the city, it took 2 years of construction with a speed up to 480 km/h and with a road length of 30.5 km and cost \$39 million per kilometer (W. Hua, 2), it as the last project for EMS technology the German company closed in 2008 because of financial problems and so we can analyze that the main factor for failure of the company is the cost and the speed, it was extremely expensive for constructing such a same project, the speed of the train still one of the fastest in the world but it's not as planned with a speed of 480 km/h while the running speed of the train now is not more than 300 km/h because of control issues. So EMS technology is not the right technology for implementing a maglev vehicle for shipping and passengers. EDS and as it is known SC Maglev is the second technology in levitation is still improving, nowadays with the last version of SC Maglev L0 Series that reaches 603 km/h in a testing line in 2015 (L.Saniz, 2015), this project was started in 2013 and it will end in 2027 connecting Tokyo with Nagoya with a road length of 285.6 km, that is not the only project for EDS technology there is a project waiting to be lunch in the USA that's going to connect New York with Washington DC this project road length 290 km more advantage for this technology is the usage of power which is less than EDS by 30% and advantage in weight capacity which uses superconductor that gives a plus for the system with zero resistance (P.Guglielmi, 2012), using superconductors have snag which is the cooling needed 42 Kalvin, in September 2020 a new mechanism of superconductivity called g-wave, in a room-temperature superconductor at 15 °C was reported in a carbonaceous sulfur hydride at very high pressure 267 GPa triggered into crystallization via green laser. This new research will solve the problem of cooling to make it cheaper to install (NN.Rivera, 2007).



After comparing the two systems and knowing the characterized both of them, using the EDS is better from different perspectives starting from the speed that can reach 600 km/h, the high amount of capacity that superconductor can levitate and the improvement in superconductor technology, the last improvement is the ability to work at room temperature instead of 42 Kelvin (F.Moura, 2013), this improvement in temperature will decrease the cost of construction of a SC Maglev system. After taking those facets about EDS and applying them on the project the image now is clearer than before and the project going to look like.

### **3.2 Analysis**

The analysis is divided into two parts the survey that have taken place over 300 participant by asking them questions about their experience in shipping and using of transportation systems and if they prefer using a faster transportation system for traveling and shipments. The second part is the software analysis which is the results of the simulation using the MatLab software for controlling the levitation of the vehicle and the control of the speeding system of the vehicle which is automated.

#### **3.2.1 Survey analysis**

For this project a survey is done with 300 people were part of it, those people are living in Istanbul or Ankara and the results of the questions were as follow, Starting the survey by the most used transportation system and as it is mentioned down in figure1, the most used transportation is the bus by 56.3% and the second transportation system by using is the metro. 43.8% of people prefer to use the metro because it's faster than the other transportation systems as we can see in figure 3.11, 33% of people rated the speed of the transporting system less than 6 over 10. For the safety of the transportation system, 35% of people gave it 8 over 10. 38% of people said that the transportation system is expensive. 45% of people travel between cities and 26% of people who are living in Istanbul travel to Ankara, Most of cities travelers uses the bus about 55.2% and 38% use the airplane, who uses the bus because it's cheaper and who uses the airplane because it's faster. About 74% of people prefer using eco-friendly transportation system and the rest maybe will use it according to the price. 54% of people use cargo shipping services and 21% use it indirect way. The satisfaction of the shipping and delivery process most of the

ratings are under 8 over 10. About the dating of the delivery schedule, 40% give it 8 over 10. About 30% of people gave 6 over 10 for the quality of product upon delivery.

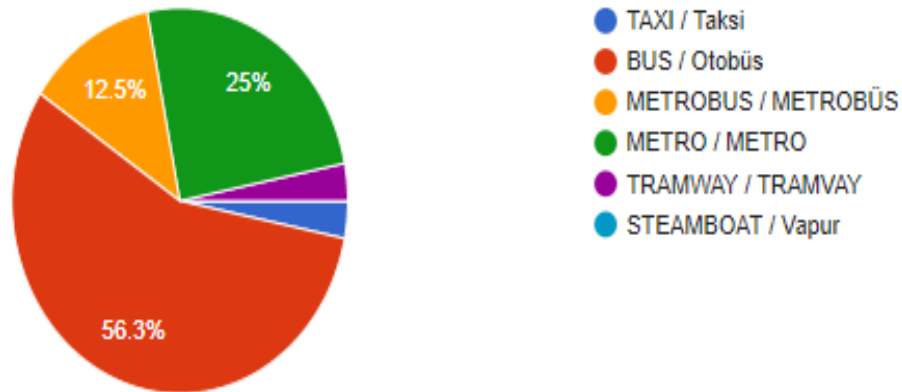

**Figure 3.1:** Percentage of the Transportation System That Used the Most

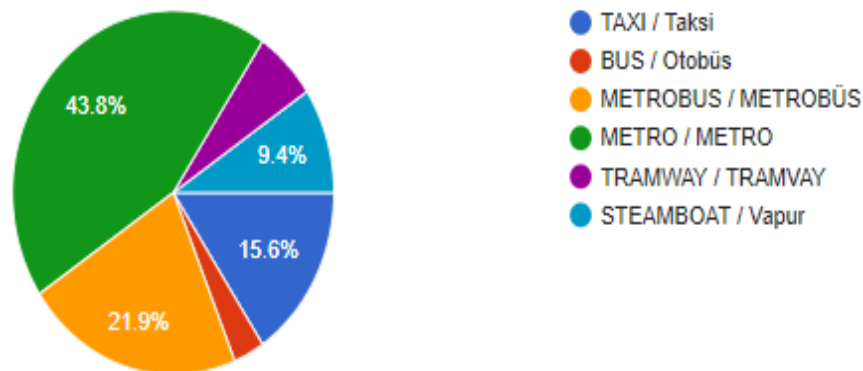

**Figure 3.2:** Percentage of People that Prefer to Metro with Other Transportation Systems

By focusing on some questions in this survey starting from the most preferred transportation system to travelers which is metro and when we want to know why metro because the metro is faster than the others with having its own track so there is now traffic, timing is accurate most of the time and can move huge amount of people in the Sometimes and the most important thing that people focus on price, the metro tickets price is not an expensive transportation system. Allowing to be available for all community layers while the airplane considered expensive for many of the community layers. According to the survey, the participants gave the transportation systems speed rate 6/10 which is a really low rating and that because of traffic and the numbers of cars that are using the same track with the buses and the metro have their own track but have speeding limit, the fastest train in turkey is

(Yüksek Hızlı Tren) that connect Istanbul with Ankara its maximum speed is 250 km/h and this speed can only be researched for 10% of the time needed from Istanbul to Ankara. Further this train is only designed for passengers and it can't ship any shipments between the two cities, there's only two ways to ship the shipments by six-wheel that takes 7 hours or by the airplane that need 1hour and 20 minutes without calculating the time needed for arrival and departure of the plan. In both cases, it takes more time than the SC Maglev train that can reach the same distance with less than 1 hour and it be used for passengers and shipments with the convertible SC Maglev system that can change the cabin of the SC Maglev from passenger cabin to shipments cabin.

As we know the climate change one of the biggest problem we are facing in this century and the real improvement we are making is using of eco-friendly systems in many sectors, the transportation system is one of them about 28% of the pollution comes from the transportation system, the way people thinks make a big deference since they are the main users of it, and according to the survey 74% prefer using eco-friendly transportation system. That's can be great in order to decrease the emotions.

According to survey most of the participants gave a rate of 6/10 for the speed of the shipments and the quality, can show that there is a problem issue in the used system nowadays. Knowing the 5 steps of shipping the products which starts with the first step picking up the products the next step is origin this stage covers the activates between pickup and loading onto the vessel, main transit is the third step of the system and it's the main leg of the shipment, where the products shipped from city to city or country to country, the fourth step is destination and it's about repeating but in reverse, namely, unloading, deconsolidation, and customs clearance the final step is delivering when the shipment is transported from the warehouse to your shipment's final destination. During this procedure, we can figure out that the third step main transit have a biggest effect on the whole process since in this step the shipment is on the way to be delivered and the factor here is the speed of the system used to deliver the shipment.

### **3.2.2 Controlling system (magnetic levitation)**

The technology of Magnetic levitation is used for controlling and achieving the best performance for the motion systems, such as suspension, precision positioning and

manipulation. No contact, no pollution and tactile response caused by several degrees of freedom (DOF) (C. Muneera, 2016). One of the features of the Maglev system is that it reduces the imagination, which makes it interesting in real-life applications namely transmission system, wind tunnel passage, magnetic bearing system and anti-vibration table.

These systems are nonlinear and unstable by nature. As a result, the magnetic levitation system provides an intriguing topic for testing the control chart's performance. To regulate these systems, however, a variety of methods are used. In a genuine magnetic system with a PID controller. It has been used to model a system in a multilayer feed-forward neural network, in which understanding and control occur simultaneously. Some of them are based on neural networks. Design and implementation of an active pattern recognition neural network. Likewise, efficient technology for adaptive controllers (KA.Small, 2007). The nerve controller is designed in a stable nonlinear system. An ideal controller based on a new iterative dynamic programming has been proposed and tested. Various PI control methods have been designed and tested (R. Batly, 2013).

However, the maglev system has unstable nonlinear dynamics and needs to be considered. Most plugins need to measure location, velocity, and current, so state monitors must be integrated to predict signals unavailable in nonlinear dynamic systems (KM.Gwilliam, 1997). In addition, he has to design complex systems, some of which are very expensive. In view of the aforementioned work, the controller that will stabilize the system should be of great interest.

### **3.2.3 Maglev system model**

Figure 3.4 depicts the magnetic levitation system experiment. The system consists of four electromagnets that act as actuators to apply magnetic force in order to maintain a constant height and precise position control; a rigid square board with four permanent magnets on each corner, and four Hall Effect sensors that detect the position of the floating plate, which is determined by the voltage applied by the coil.

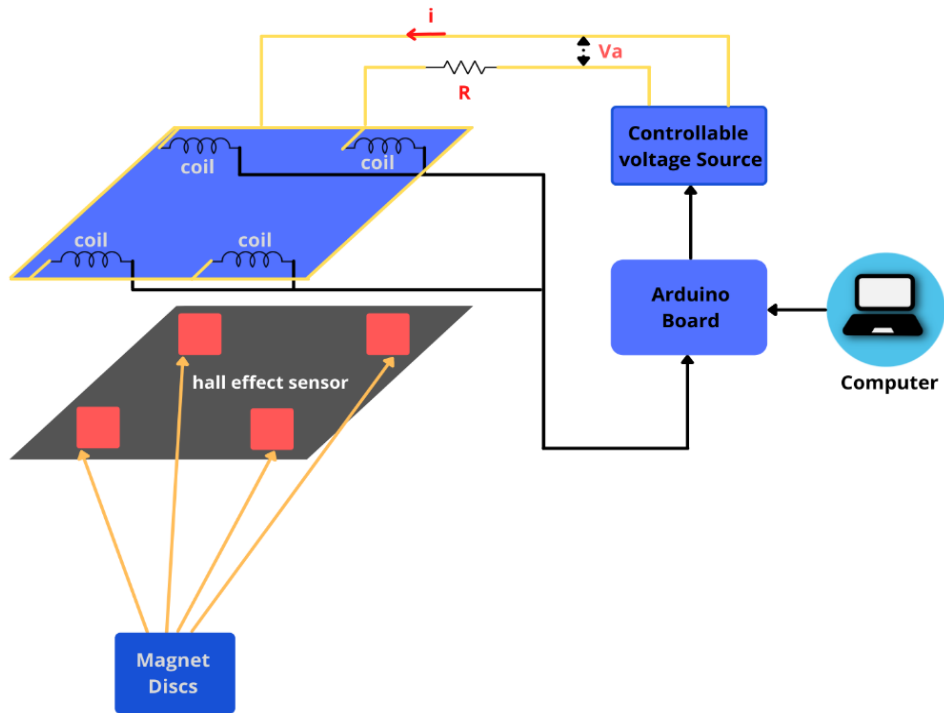

**Figure 3.3:** Body Diagram of Magnetic Levitation System

The electromagnet is a solenoid with a 15 mAh capacity and a 2 ohm internal resistance. A Hall Effect linear radiation sensor with 50V/T is a Hall Effect sensor. An N52 neodymium disc magnet with a diameter of 12.70 mm and a thickness of 6.35 mm serves as the permanent magnet. The panel is a clear acrylic board with dimensions of 152.4mm x 152.4mm x 3.175mm. Wood is used to construct the frame. The system has a quarter system architecture for ease of use and traceability (similar to a quarter car model). Figure 3.2 depicts the quadruple system model, in which  $R$  is the coil's resistance,  $L$  is its inductance,  $v$  is the electromagnet's voltage (Lix, 2015),  $I$  is the current flowing through the electromagnet, and  $m$  is the magnet's increasing mass in the air.  $g$  is attributable to gravity measured from the bottom of the electromagnet, therefore add a quarter of the mass of the acrylic plate. The force acting by the rising magnet produced by the electromagnet is  $d$  (the vertical position of the rising magnet),  $f$  is the force acting by the rising magnet generated by the electromagnet, and  $e$  is the Hall Effect. The voltage measured by the sensor.

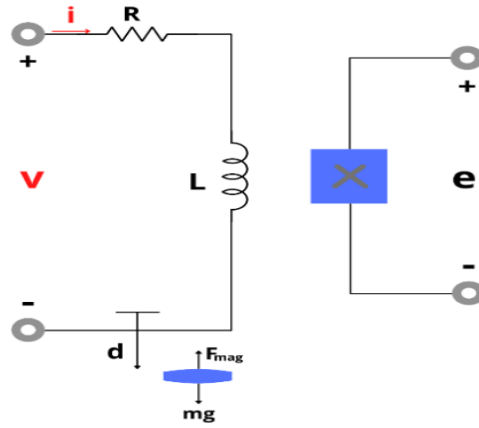

**Figure 3.4:** Electromagnetic levitation system model.

### 3.3 Control system design

This section introduces the LQR development based magnetic levitation system controller, advanced balancing and PID control as follows:

#### 3.3.1 LQR controller (Linear quadratic regulator)

By putting the closed-loop pole of the system into the desired location, the linear quadratic regulator (LQR) technique is comparable to the Root Locus method. The state space of the linearized dynamic model of EMS is as follows:

$$\dot{x}(t) = Ax(t) + Bu(t) \quad (3.1)$$

$$y(t) = Cx(t) + Du(t) \quad (3.2)$$

The state of  $X(t)$  may be monitored using the formula, and the controller's cost function can be reduced:

$$J(u) = \int_0^{+\infty} (x^T(t) Qx(t) + u^T(t) Ru(t)) dt \quad (3.3)$$

$R$  and  $Q$ 's values may be seen as a proportionate weighting matrix. The variable  $x(t)$  is deemed steady-state for the initial state, depending on the disturbance of the control system. The cost to be assigned to energy in the transient response is the first term of the  $J(u)$  function (M. Cheng, 2014).

The control signal  $u(t)$  is proportional to the given air gap in a linear manner. Likewise, it is suitable for eliminating path boundary conditions at the required operating point  $(i_0, z_0)$  during the design stage (W. Hua, 2014).

Its use can be expressed by the linear response of the following equation:

$$u(t) = -[k_p(x_1(t) - z_{ref}) + k_v(x_2(t)) + k_a(x_3(t))] \quad (3.4)$$

Among them:  $k_p$  represents the fixed error, and the damping of suspension control  $k_v$  and  $k_a$  applies to all stability margins. The limitation of linear controllers is the ability to suppress interference in the control loop. The calculated LQR gain is ( $k_p = 32,483$ ,  $k_v = 90.4$ ,  $k_a = 9.4$ ).

### 3.3.2 PID controller

Figure 3.6 shows a schematic design of a PID controller. The control system is based on calculating the error value and changing the controller's settings to decrease the error percentage. The controller's overall look formula is as follows:

$$u(t) = K_p \left( e(t) + \frac{1}{T_i} \int_0^t e(\tau) d\tau + T_d \frac{de(t)}{dt} \right) \quad (3.5)$$

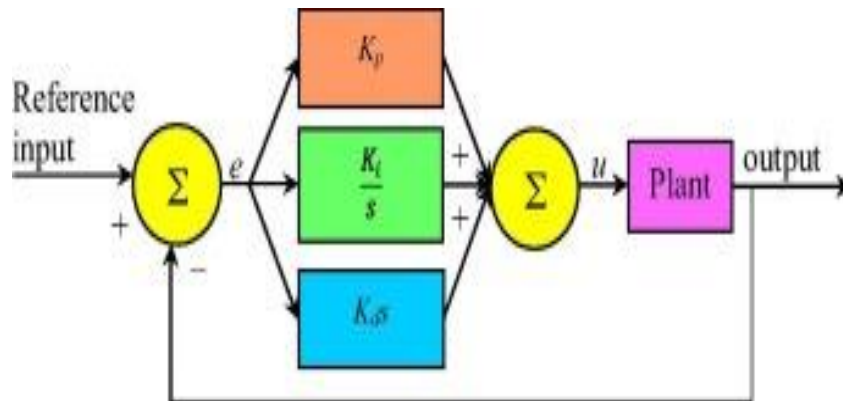

**Figure 3.5:** Block Diagram of PID Controller

$u(t)$ : Represents the control signal  $K_p$ : relative gain,

$T_i$ : integration time  $T_d$ : export time,  $K_p$ ,  $T_i$ ,  $T_d$ : setting and control parameters

$E(t)$ : The distinction between the reference point and the actual apparatus.

By setting the closed loop pole as  $P = (-132.45 \ 38.36 - 28.36j)$ , the calculated PID gain is ( $K_p = 10$ ,  $K_I = 4$ ,  $K_D = 0.2$ ).

### 3.3.3 Lead compensation

One of the most common technologies used in industrial applications is the control unit design of the primary compensation regulator. The phase lead compensation

control falls within the traditional control category. Because it is almost exclusively utilized for control feedback, it is extensively employed in industrial control systems. The primary compensation controller's major function is to decrease the error rate by changing the control system's settings (B. Boazzo, 2012). A phase compensator structure in which the transfer function is augmented with zeros and poles. It can be written like this:

$$G_c(S) = K_c \cdot \alpha \frac{T_s+1}{\alpha T_s+1} = K_c \frac{s+\frac{1}{T}}{s+\frac{1}{\phi T}} = K_c \frac{s-}{s-} \quad (3.6)$$

$G_c(s)$ : transfer function,  $(K_c, T_s)$ : control parameters, among which  $K_c$  is a short-range loop system compensator,  $Z$  is zero, and  $P$  is an electrode. It is feasible to get an improved transfer function (updated parameters) applied to the suggested electromagnetic lifting system and estimate the output of the system by integrating the transfer function of the primary compensator in Matlab (P. Guglielmi, 2012). ( $K_c = 10, Z = 30, P = 100$ ) are the estimated lead compensation parameters.

### 3.3.4 Maglev motor-Electric Synchronous linear motor

A linear drive is a type of electric motor in which the rotor and stator are "fixed", so it does not generate torque (rotation), but instead generates linear force along itself. However, the linear motor does not have to be linear. Typically, the active part of a linear actuator has an end, while a more traditional electric motor is arranged in a solid ring (A. SefaAkpınar, 2017).

Linear motor mostly use Lorentz type actuator for operation, linearly proportional is the applied force to the magnetic field and current. Like it can be in the formula:

$$(\vec{F} = I\vec{L} \times \vec{B}). \quad (3.7)$$

There is the high acceleration and the low acceleration of the linear motor are the two major categories. The low acceleration is mostly used for maglev trains.

Mainly linear synchronous motors driven by RSM. The main stator is called the RSM stator: it is called the slave rotor, which is equal to the rotor (O.Otkum, 2017). The principle of operation is the same as that of RSM. The equation used for RSM analysis is valid in LSM analysis, but with the following changes: a rotating magnetic field is converted into a moving magnetic field, torque becomes repulsive



force, synchronous rotation speed ( $\omega_{syn}$ ) becomes linear synchronous speed ( $v$ ), and the extreme difference ( $\Delta T$ ) Add is the difference between two different poles in the equation.

LSM can be double-sided or single-sided, with or without a hole, with a ferrite core or a hollow core. Secondary is a set of permanent magnets (PM), usually arranged in an alternate manner and usually attached to the load. Generally, the primary coil is a poly phase electromagnet arranged linearly to create a magnetic field moving in the air gap. It is usually fixed and installed along the rail (Y.Han, 2013).

### **Superconducting Coils:**

The magnetic field generated by the magnet can be strong when removed, but it will be greatly weakened. To obtain a magnetic field with a strong and large volume, an electromagnet is needed, that is, a coil of metal wire into which a current will flow. The current flowing creates magnetic field in the circuit perpendicular to the size of each coil section (GR. Slemon, 1978).

A large current is required to have a strong magnetic field. However, resistance will be generated when there is current, and heat will be generated due to the Joule effect when there is resistance. If the current is too high, the coil will melt. To avoid this problem, we can cool the wires with water (expensive and inconvenient), or use superconducting wires, because superconducting wires are not resistant to corrosion and therefore do not generate heat. The magnetic field can be obtained from a few tesla (1 tesla is approximately 10,000 times the earth's magnetic field) (HK.Sung, 2015), using a coil, thousands of turns of superconducting wire are immersed in liquid helium. These wires are usually made of niobium titanium (NbTi) or niobium tin alloy (Nb<sub>3</sub>Sn). Due to language abuse, these files are often referred to as "superconducting magnets."

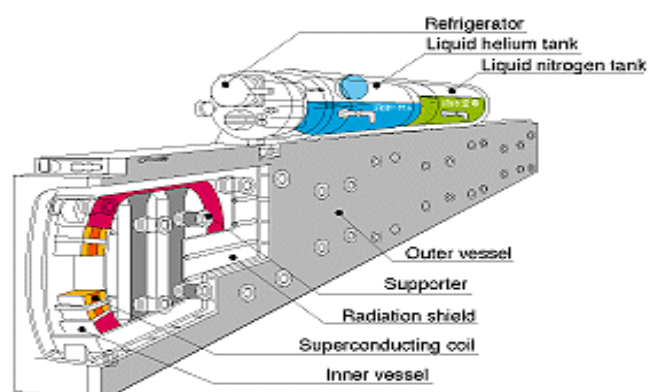

### **Figure 3.6: Superconducting Coil**

**Source:** AKG, cooling systems for rolling stock

Place superconducting coils on the vehicle sides for efficiency; four coils are fitted on each side. These coils, like those used in magnetic resonance imaging, are composed of typical superconductors and need extremely low temperatures, only a few Kelvin above absolute zero, therefore they are always encased in liquid helium. These superconducting coils receive 700,000 DC amperes, providing a powerful magnetic field of around 5 Tesla, 100,000 times stronger than the Earth's magnetic field. The magnetic field created by the superconducting coils on either side is stable and does not fluctuate over time (D. Wang, 2017).

The magnetic levitation rises and passes down the track through the metal coils in the beam due to the magnetic field created by these coils. Pusher and lifter reels are the two types of reels.

The motion coils are active, which suggests that they get power, which makes logical. The train needs to accelerate in order to overcome air resistance. These coils consume energy because they are made of metal. However, it is fully controllable: by controlling the direction and strength of the current flowing through it, the signal and strength of the generated magnetic field are also controlled (CL. Shao, 2016). To accelerate magnetic levitation, simply transfer an electric current to attract an electric current in a motor coil located in the beam in front of the magnetic height. And send to downstream coil to drive current. The magnetic lift is pulled from the front and pushed from the back so it speeds up. Thus, the locomotive of the magnetically raised train stands on the rails! To slow down, we just need to change the direction of the current, magnetically push and pull the front of the suspension train. In addition, the stroller is equipped with pneumatic brakes to slow down without consuming energy (T. Kakinoko, 2016).

As the name suggests, the downloaded file allows magnetic levitation to be raised. They are also formed of metal, but unlike the driving coils, they are not connected to any power source. It's a closed loop that's fully negative. When magnetic levitation passes through the drive coil, the magnetic field it carries (produced by the superconducting coil) wears the lift coil away (SM. Jang, 2007). Short-circuiting these coils causes an induced current to flow through them, similar to the eddy current that occurs when a magnet falls into a copper tube in the experiment. By

flowing through the coil, these induced currents produce a magnetic field. The magnetic field created by the induced current provides the buoyancy of the superconducting coil in the cockpit, thanks to the geometry of the lifting coil. (T. Kakinoko, 2016).

### 3.3.5 Studying case from Istanbul to Ankara including system cost & capacity

Turkey, located between Asia and Europe and Istanbul is divided between Asia and Europe, as shown in the figure 3.6. Its size in the center of the earth is estimated to be 783,562 square kilometers. Turkey northeastern Georgia and Armenia, Azerbaijan and Iran in the east, southeast and northwest borders with Iraq and Syria, Greece and Bulgaria. In the last 20 years, Turkey's economy has grown by 20% and up to 17th in the world in terms of nominal GDP in 2020, and Turkey will take place 13th in PPP GDP and her agricultural products, textiles and automobiles will make one of the main manufacturers. Transport and construction equipment. Supplies, appliances and appliances. Turkey's population of 65 million in 2000 and 2020, the compound growth rate of 1.47%, reaching 84 million (Cia World Factbook, 2016).

The Istanbul-Ankara YHT train was opened for public in March 2019 and managed by Turkish state railways. It traverses Istanbul to Ankara covering 561 km with a trip time in 4 hours and 30 minutes, the airplane takes about an hour and it is considered the fastest transportation system to travel from Istanbul to Ankara while the other transportation systems like bus will take 6 hours and 30 minutes and car will take 5 hours and 15 minutes (TCDD, 2020).



**Figure 3.7:** Istanbul-Ankara corridor, hızlı tren railway

Source: Historynaut, Turkish state railways

### 3.4 Spreadsheet Cost

The goal of this study is to calculate the entire social cost of a new SC Maglev line and apply it to the Istanbul-Ankara corridor in Turkey using a Microsoft Excel spreadsheet cost model. However, the estimated total annual passenger traffic and three types of cargo containers are used to calculate the estimated overall societal cost.

The development and maintenance of infrastructure, as well as the procurement, maintenance, and operation of railway equipment, are all included in operational expenses. The price of a maglev train is defined by its qualities as well as an elevator that will replace the container and passenger compartment at the time of purchase. Train capacity and unit cost are included. Moreover, operating costs, the amount of energy consumed to operate the trains, and the number of trains on a particular route all influence labor costs. The cost of rolling maintenance is determined by the fleet size, manpower, materials, spare parts, and train usage (in relation to the total distance traveled by each train per year). Second, user expenses are mostly determined by door-to-door travel expenses, which include arrival, waiting, transit, and leave times, as well as no monetary cost. Finally, air pollution, accidents, noise, and climate change are examples of external societal costs (Siemens, 2016).

The cost of operating a maglev line is primarily determined by the cost of developing the infrastructure, which is separated into two sections. First, because the maglev line must double in return on capital, the ratio of the building cost utilized for construction and the length of the maglev line determines the cost of establishing the infrastructure. As demonstrated in Equation 3.8, return on capital is employed to transform operational expenses into yearly expenses in this model.

$$A = P \left[ \frac{i(1+i)^n}{(1+i)^n - 1} \right] \quad (3.8)$$

However, as shown in Equation 3.9, the return on capital ratio is used for the cost of building the infrastructure to convert it into an annual cost.

$$(IC_C) = L[c_c(1+\rho)] \times \left[ \frac{i(1+i)^n}{(1+i)^n - 1} \right] \quad (3.9)$$

ICC = Maglev Line Infrastructure Construction Cost (\$ / km)

L = Length of a certain magnetic lift line (km)

cc = Cost of constructing this maglev line unit (\$ / km)

$\rho$  = percentage of construction cost used for designing (percentage)

P = current cost of the magnetic lift line (\$)

A = Annual cost (USD / year)

Second, cost of infrastructure maintenance is an annual unit that may be calculated using Formula 3.10.

$$(IM_c) = L \times c_m \quad (3.10)$$

IMc = Maglev line infrastructure maintenance cost (USD / year).

Cm = normal service unit cost for maglev line (\$ / km)

The purchase, operation, and maintenance of the trains required to offer services along the route are broken down into three categories. The price of rolling stock is determined by a variety of technical factors, including the capacity (number of seats), delivery and payment conditions, and the train operator-manufacturer pricing contract. In this scenario, some train operators choose to develop their rolling stock in-house, while others prefer to contract it out. The capacity of a maglev train, on the other hand, is determined by the maximum number of trains (that can be handled on a specific route) necessary over a particular length of time, as well as the size of the maglev truck (seats) in operation. There is also the quantity of cargoes that the train can carry. To assess the entire societal cost of SC Maglev, projections for the system as a regular passenger train and shipping system are required. However, a regression model was used to assess the trip requirements for the planned high-speed rail link between Istanbul and Ankara, two significant Turkish cities separated by 450 kilometers. The suggested flexibility between the high-speed rail and the MV. Line, as indicated in Equation 3.11, may be utilized to forecast the requirement to relocate the MV line depending on the number of flights and the generalized flight duration.

$$\text{Forecast change } (F_c) = \frac{T_M}{T_{HSR}} = \left( \frac{GJT_M}{GJT_{HSR}} \right)^E \quad (3.11)$$

TM = number of SC Maglev (train) trips

THSR = Number of trips by high-speed train (train)

GJTM = Generalized magnetic flight time (minutes)

GJTHSR = Total travel time for high-speed rail (minutes)

E = generalized travel time elasticity

In this case, the total travel time depends on the time in the car and the service interval time, which can be calculated using formulas 3.12 and 3.13:

$$GJT = IVT + \text{Service Interval penalty} \quad (3.12)$$

$$GJT = \frac{\text{Distance}}{\text{Speed}} + \frac{60}{\text{Service frequency}} \quad (3.13)$$

Shift frequency, on the other hand, is mostly determined by the total number of daily trips in each direction, which is calculated based on predicted demand and effective train utilization. The train capacity is multiplied by the average load factor, and each shift is multiplied by the frequency, the total train load can be calculated. (CJRC, 2012). The service is to calculate a straight line that changes over time, as shown in equation 3.14:

$$F_t = \frac{Q_t}{O_d \times Q_e} \quad (3.14)$$

$F_t$  = Frequency of lane service per time period (train / hour)

$t$  = year (s) since the year of operation ( $n$ ) of the specified magnetic suspension line

$Q_t$  = Daily (one way) forecast of demand (passengers & shipments)

$O_d$  = daily working time (hours)

$Q_e$  = actual employment (place)

In addition, as illustrated in equation, the effective occupation is determined 3.15.

$$Q_e = I \times C \quad (3.15)$$

$I$  = Load factor (percentage)

$c$  = Train capacity (shipments + seats)

As indicated in equation, 3.16 may also be used to estimate the number of travelers per day and per direction.

$$Q_t = \frac{ID_a}{N \times \text{days / year}} \quad (3.16)$$

At = expected daily demand (one-way) (traveler)

IDa = Initial annual demand (passenger / year)

I = the direction number

As indicated in equation, the number of trains per day-direction (train) may be calculated. 3.17.

$$NS = Q_t / Q_e \quad (3.17)$$

In this project, the number of trains per day is needed to calculate the hourly service frequency, as mentioned in Equation 3.18:

$$F_t = \frac{Q_t}{O_d \times Q_e} \quad (3.18)$$

The trains total number is required to travel on a superconductor, may be computed using the formula provided in Formula 3.19, This is mostly determined by the amount of people on board and the quantity of the shipments with the number of trains (69).

$$RS_t = (1.5) \times \tau \frac{Q_t}{O_d \times Q_e} \quad (3.19)$$

RS<sub>t</sub> = number of trains purchased in year t of observation period (trains)

τ = maglev train rotation time (hours / train)

v = average commercial velocity (km / h)

It is necessary to use 40 seconds to determine the cycle times of the SC Maglev train for the start and in order to determine the number of trains received at the end of the journey, as illustrated in equation 3.20.

$$\tau = 2 \times (L / v) + (20 + 20) / 60 \text{min} \quad (3.20)$$

Contracting, design, building, delivery, and testing for new rolling stock often takes many years, especially if demand forecasts are established ahead of time. The cost of a SC Maglev train, on the other hand, is frequently based on the volume of cargoes and the number of passenger seats. (H.T, 1994). Increase the number of trains per

year by the average train capacity plus the unit cost per seat or shipment in this scenario, as indicated in Equation 3.21.

$$RSC_A = [RS_t \times c_A \times \bar{q}] \times \left[ \frac{i(1+i)^n}{(1+i)^n - 1} \right] \quad (3.21)$$

RSCA = Rolling Stock Purchase Cost (\$ / year)

CA = cost per unit of purchase of railway rolling stock (\$ / seat or 80kg)

q = Average train capacity (seats or shipments)

The cost of operating the rolling stock mainly depends on the projected traffic volume, as it includes labor costs, energy costs, sales and management costs on the train. In Formula 3.22, the number of trains and daily operating hours are included in the cost of operating rolling stock to meet passenger needs and the shipments that should be delivered (69), and the value 2 represents the number of destinations.

$$RSCO = 2 \times CO \times Ft \times q \times L \quad (3.22)$$

RSCO = Rolling Stock running Cost (\$ / year)

CO = Average unit cost of wagon operation (\$ / seat or 80 kg - km)

The cost of maintaining Maglev rolling equipment is determined using Equation E16, which takes into account the number of trains, their use over time, and the average unit maintenance cost 3.23.

$$RSCM = CM \times ut \times q \times RSt \quad (3.23)$$

RSCM= represents the yearly cost of rolling stock maintenance (in dollars).

ut = average train usage in the year t of the observed period (km / location).

CM = wagon maintenance unit cost (\$/seat or 80 kg/km)

The user cost is mostly determined by the amount of time spent traveling and is factored into the total social cost estimate. A user's trip time is divided into multiple categories in transportation research, include time spent walking (arrival / exit), time spent waiting, and time spent in the vehicle. In fig. 8, Arrival time is the total time it takes to travel from the exit point to SC Maglev Station (A), and Exit time is the whole time it takes to travel from to the location, take the SC Maglev Station (B). The time spent by the automobile and the time spent waiting at the station are shown



by the track line (Elaine, 2008). The same factor will be applied in the shipment case, but there will be a factor that is the time required to change the passenger's cabin with the shipment container, and this operation can take place in either the origin or destination part. The cost will be calculated by kg, and it can be as low as \$1 per 80 kg, which is the average weight for one seat.



**Figure 3.8:** The Overall Travel Time Structure

The time it takes to travel from one's front door (home, work, etc.) to the city's primary transport infrastructure is referred to as arrival time (A). A journey to a metro station, bus station, railway station, airport station, or other location. This is the time it took to get there. A traveler's arrival time for Maglev transit might relate to time spent in a bus, subway, or auto (for example, a private automobile or a taxi).

The exit time is defined as the time it takes to go from the city's first transportation infrastructure (B) to the end destination. The primary variation in arrival and departure time in this situation is mostly due to the departure and arrival of the superconductor lift station. The superconductor departure time is 32% longer than the arrival time, which may be related to people being more familiar with transportation options. In terms of long-distance travel.

Arrival times can include any public transport services (such as buses, metros, etc.) and other access options other than pedestrian access. According to some studies, the walking time factor is nearly twice the length of the car trip.

In this case, the time of arrival and exit of each passenger depends mainly on the average attainable entry and exit distances and average travel speeds, as shown in Equation 3.24.

$$TAE = DAE / VAE \quad (3.24)$$

Where:

TAE = average arrival/departure time per passenger (hours)

DAE = average entry/exit distance of SC Maglev station (km)

VAE = average speed of travel (km/h)

The total arrival and exit times must be computed on an annual basis, and the average entrance and departure times per passenger may be obtained by multiplying the total number of passengers per year by the average entrance and departure times per passenger. The average arrival / exit time for superconductor station entry / departure must be multiplied by two in this scenario, as illustrated in Equation 3.25.

$$TTAE = 2 \times Q_t \times TAE \quad (3.25)$$

TTAE = total yearly passenger arrival/departure time (in hours)

$Q_t$  = at time t, passenger demand in each direction (passengers/year)

For all public transport, one of the most crucial parts of a user's total cost is waiting time, because waiting time begins when passengers board the bus and when they arrive at the terminal. However, waiting time is a key factor in evaluating passenger service, because rail passengers often face different types of waiting for different reasons. In case of a train is delayed, the waiting time may be longer, and most trains will experience some delays during rush hours. In the case of waiting the train, the time value is roughly related to the travel time, which means that one minute of the waiting time estimated by the passengers is equivalent to 2.5 minutes of the journey. Although the average waiting time can be approximated as part of the journey, it is computed by dividing the working day's length by the frequency of service. As a consequence, the waiting time for passengers may be determined by taking a half-way journey, as shown in Figure 3.26.

$$TWT = \frac{1}{2} \times \text{Headway} \quad (3.26)$$

TWT = Average Waiting Time per Passenger (Hours)

$F_t$  = lane maintenance frequency (train / hour) over a period of time

The entire yearly waiting time is determined using the yearly needs as indicated in Equation to determine the value of maglev passenger service on an annual basis 3.27.

$$TTWT = Q \times TWT \quad (3.27)$$

TTWT = total annual passenger waiting time (hours)

Q = for the time period t, passenger demand is expected to be high (passengers or 80 kg per year)

The amount of time spent on the superconductor train is mostly determined by the average track length and average speed ( $v$ ). The settling time is not included since the SCMaglev train has no intermediate stops, therefore the average travel time of the vehicle may simply be computed by dividing the average trip distance by the average speed, as shown in Equation 3.28.

$$TIV = L / V \quad (3.28)$$

TIV = Average time per passenger in the car (hours)

L = the selected SC Maglev line's average length (kilometers)

V = Typical driving speed (km / h)

The average passenger travel time, the average SC Maglev operating speed, and the yearly passenger need may all be used to compute the yearly HSR passenger trip time in a vehicle, as illustrated in Equation 3.29.

$$TTIV = Q_t \times TIV \quad (3.29)$$

TIV = the amount of time individuals spend in their cars on a yearly basis (in hour)

$Q_t$  = Passenger demand in each direction at time  $t$  (passenger or kg / year)

The value of time (VOT) is an essential component to consider when managing and accessing transportation investment decisions. It is also one of the most significant aspects to consider when analyzing travel demand patterns. It's also known as the price consumers are willing to pay for having more time units, and the readiness to pay for the difference in time between two forms of transportation determines the value of saving time. (JRC, 2016).

You can also think of VOT as one of the key outcomes to learn from a particular preference experience related to being willing to pay in order to save time. Personal travel time value varies depending on the scenario and might vary from 20% to 90% of the overall salary rate, on average around 50%, and business trips are usually higher. In this case, the walking time (entry / exit) and waiting time are 1.6–2 times longer than the time on board.

Travel time for railways, highways and buses estimated based on state election data used by the Turkish national price level estimation model in 2020 is 1.5 \$ / hour, 1\$ / hour and 0.75\$ / hour, respectively. However, as the Netherlands and Sweden point

out and suggest, saving time can be more valuable on long journeys. Lower time values, on the other hand, might be employed to save time on short excursions, in which case time spent by employees to save time must be assessed appropriately. The value of time, according to Verhoeven, is included in the wage rate.

As an example, with respect to business and employer travel expenses, the time value equals 1.33 of the hourly rate, while for short round trips (less than an hour round trip) one-third and two-thirds of the long time is required - travel distance. Calculate the average hourly wage as given in this Equation 3.30.

$$AWR = \frac{\text{average monthly wage rate}}{\text{average working hour per month}} \quad (3.30)$$

The overall user cost has been mainly linked to generic time in the previous sections (including walking time, waiting time, and flight time), and then multiplied by the time value shown in Equation 3.31, and then converted to total cost.

$$TUC = [(w_{AE} \times TT_{AE}) + (w_{wt} \times TT_{WT}) + TT_{IV}] \times V \quad (3.31)$$

TUC = Annual Total User Cost (USD / year)

WAE = coefficient representing weight perception and arrival / departure times.

Time in the car (amount)

Wwt = coefficient representing waiting time and weight in the vehicle.

Time (number)

VOT = duration of a maglev train (\$ / hour)

External environmental costs, such as air pollution, noise, accidents, and climate change, are defined as transportation-related expenses that are driven by the environment, people, and society as a whole, because they generally refer to the gap between internal and societal expenses, the community and the transport user are impossible without governmental involvement. Internal expenditures such as vehicle energy expenses, transportation charges and taxes, wear and tear, and special time are all accepted directly by the transport user in this situation. Location, peak / off-peak hours, and vehicle features, on the other hand, have a significant impact on foreign transportation costs.

In addition, in the calculation of outdoor cost, vehicle mileage and perimeter unit are used, which allow the measurement of external costs arising from the operational

performance of transportation technology, which were used in previous environmental cost studies. External environmental costs, for example, may be determined by multiplying the total number of passengers per kilometer by the sum of air pollution, noise, accident, and climate change costs, as indicated in equation 3.32.

$$\text{Total External Costs (TEC)} = \text{PKM} \times (\text{UCC}_c + \text{UNP}_c + \text{UAc} + \text{UAP}_c) \quad (3.32)$$

$\text{UAP}_c$  = cost of air pollution per passenger kilometer as a unit (\$ / pkm)

$\text{UNP}_c$  = The cost of noise pollution per passenger kilometer is (\$ / pkm)

$\text{UAc}$  = Costs per passenger-kilometer for emergency vehicles (\$ / pkm)

$\text{UCC}_c$  = Cost of climate change per traveler in kilometers (\$ / pkm)

$\text{PKM}$  = per kilometer total number of passengers

Purchasing power parity should be used to establish the unit cost of a car's external cost per kilometer (PPP). PPP stands for purchasing power parity, which is an economic theory that considers currency parity and buying power pressures across nations.

The need of a fast transportation and shipping system between Istanbul and Ankara is increasing since Istanbul is the economic city and Ankara is the politic city moreover those two 2 cities contain more than 20% of the Turkish population, from the population of the two cities to the increasing of the economies of Turkey that according to the British financial institution Standard Chartered, it's going to be one of the top 5 economics in 2030 (GDP. Composition, 2016), this can shows the size of the Turkish economic and the importance of a fast system that can be the bridge between them. Here's come the SC Maglev system that can be used as a transportation and shipping system, it can travel with a speed up to 500 km/h that can cross the distance between Istanbul and Ankara in only 62 minutes. This system is not a normal train like the one in japan since it contains a system that can change the passengers cabins with and containers that contains the shipments, this system can work according to the need or it can be programed daily it can carry passengers during the day time and at night it can carry the shipments. In specific hours when workers are going or leaving work place it should be used as a passenger's cabin and in the rest of the day it can used as shipping containers. This system can change the overcrowding in Istanbul and it will create new cities near the maglev line, moreover

Employees who are working in Istanbul can move to live out of Istanbul which is impossible nowadays but by building the SC Maglev, new cities will appear and the time needed between the two cities will be only between 62 and 70 minutes.

## Results

In order to predict the initial annual demand for the proposed line in the first year of operation, the generalized traveling time for both SC Maglev and HSR must be calculated using the elasticity of  $-0.9$  for non-Istanbul ticket holders over 32 km. As demonstrated at the Emsland Test Track Line in Japan, the SC Maglev system was selected for its technical stability and reliability. The frequency of the SC Maglev service, on the other hand, was calculated with an initial demand of 18,000 passengers per day and a frequency of 1.25 trains per hour, with a distance of 451 kilometers, the Istanbul-Ankara SC Maglev case study might be rounded to one train every hour, yielding a headway of 62 minutes each trip. A time penalty of roughly 15 minutes would be incurred as a result of this.

Given the aforementioned, it is projected that one train will run every hour in order to introduce operational flexibility, with a 14-minute equivalent time penalty according to the passenger demand forecasting handbook. The time penalty for a 15-minute service break is 14 minutes. It's also utilized to calculate the overall travel time of the SC Maglev system at 500 km/h, because there's no interchange along the proposed 451-kilometer Istanbul-Ankara line.

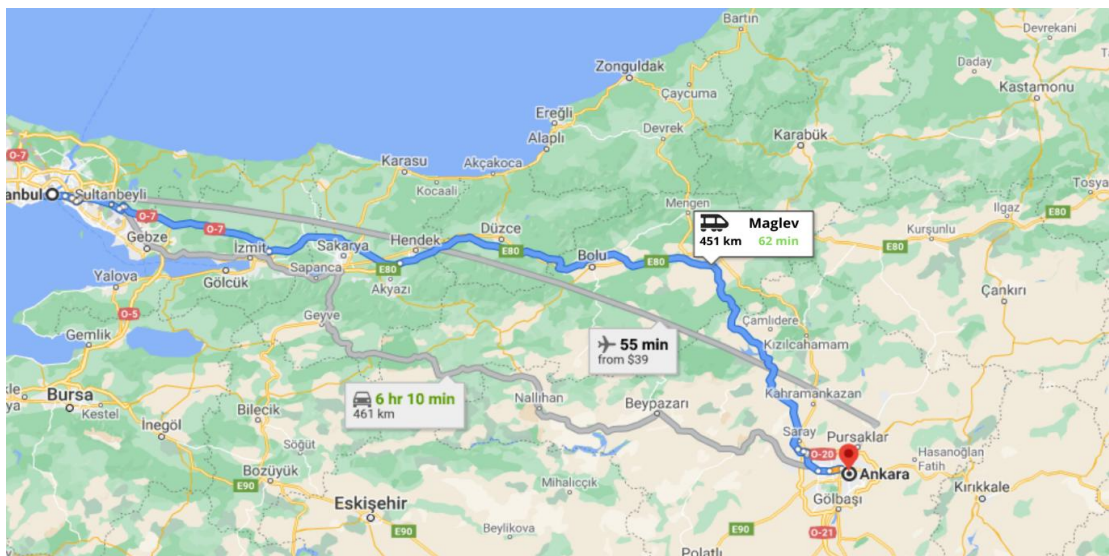
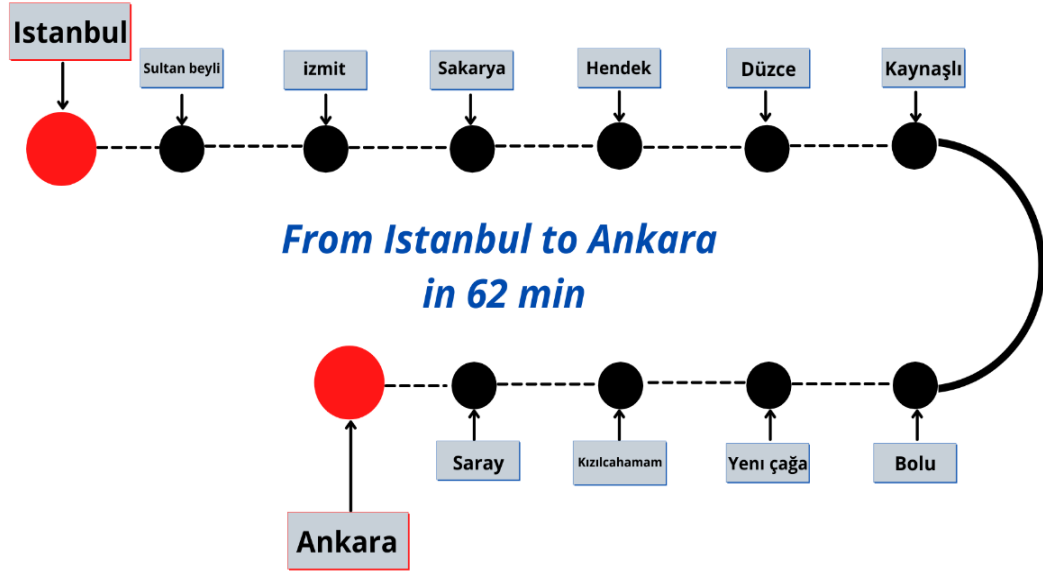

Figure 3.9: Maglev road map

The figure 3.10 map shows the road of the SC Maglev and the cities it will pass through with a distance of 451 km, considering stations will be available in 10 cities on the way of the SC Maglev from Istanbul to Ankara as shown in figure 3.1.



**Figure 3.10:** Cities SC Maglev Train will pass through

**Table 3.1:** Forecasting Service Frequency Changes

Category	YHT	SC Maglev
Time spent in the car	210 min	62 min
Service	0.28/hour	0.98/hour
reciprocate	0	0
Total GJT	224 min	76 min

Due to the generalized flight time elasticity, the expected demand change is shown in Equation 3.26.

$$F_c = \left[ \frac{76}{210} \right]^{-0.09} = 1.246 = \frac{4}{3.21} = 1.246 \quad (3.33)$$

This means that the SC Maglev trains will be operated at their maximum capacity, therefore, the change of service is expected to increase the demand for maglev trains by 25% (3.25 million passengers or the Weight of the shipments by 263.25 kiloton). With the increase in the number of trains on the SC Maglev line, the number of daily trains in this direction reached 23 trains per day, while the number of YHT trains was 6.8 per day.

Due to the increase in the service frequency from 7 for the YHT railways to 23 trains, as shown in Table 3.1 above. The SC Maglev train travels at a speed of one train per hour. The Chuo Shinkansen Line is estimated to cost \$60 million per kilometer to build. SC Maglev superconductor trains, on the other hand, generally transport roughly 1,000 passengers per trip when employing a conventional seating layout. The yearly maintenance cost of the recommended superconductor line, on the other hand, is 14900 dollars per kilometer, due to the lack of friction, which is one of the reasons for the cheap cost. The average unit cost for the purchase, operation and maintenance of SC Maglev trains is 60000\$ per seat, 12\$ per kilometer run and 0.013\$ per kilometer, two double girder gantry crane needed one in Istanbul and one in Ankara it is used to lift and lower the container from or to the Maglev rail. The cost shown in Table 3.2.

**Table 3.2:** Forecasting Service Frequency Changes

Classification	Cost	Unit
Cost of constructing a single SC Maglev	60 000 000	\$/km
Cost of maintaining a certain SC Maglev on a regular basis	14 900	\$/year
The cost per unit of obtaining a Maglev	60 000	\$/seat
The annual shipping unit cost in kg	740	\$/kg
Average unit cost of operating a Maglev train set	12	\$/seat-km
Average unit cost of maintaining a Maglev train set	0.013	\$/seat-km
Two Double girder gantry crane	250 000	\$/crane

Table 3.2. shows the Infrastructure, construction, and maintenance unit costs, as well as the capital recovery factor (0.06), are calculated using 35 years of operation and a societal discount rate of 5%. Infrastructure is estimated to cost approximately \$ 27.1 billion in total (including maintenance). Based on the operating cycle time, probability of failure (1.5), and service frequency of one train per hour, about 23 SC Maglev trains are purchased each day. The value of time connected with business and commuting trips is primarily determined by access/egress time, waiting time, and in-vehicle time in terms of user cost.

The lengths and travel speeds to/from SC Maglev stations are calculated in this scenario utilizing city speed restrictions of 60 km and 80 km/h, respectively, to give a 4 hour and 33 minute access/egress time by car. Furthermore, the in-vehicle travel



time is calculated using a distance of 451 km and a speed of 500 km/h, resulting in a 62-minute duration, while the waiting time is calculated using half of the headway, resulting in a 14-minute duration. The SC Maglev train is expected to have no external environmental impacts in terms of air pollution or noise pollution. Due to a comparable number of accidents and a total passenger-kilometer of 6.77 billion, the SC Maglev system will incur the same external cost as the YHT system in terms of unit accident, which is \$ 2 per 1000 passenger-kilometers. In this example, the average annual cost of an accident on the SC Maglev line is \$ 10.72 million. SC Maglev also utilizes less energy per kilometer than YHT, resulting in a \$ 4 million annual climate change effect, compared to \$ 9.82 million for HSR.

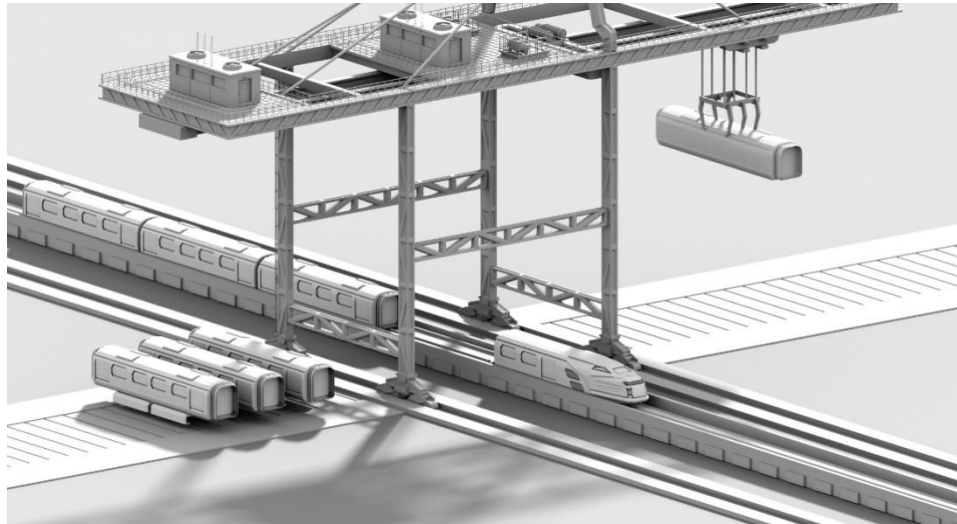

**Figure 3.11:** Final Istanbul- Ankara Design Concept

#### 4. CONCLUSION

The elasticity methodology must be used to predict travel demand for the planned Yüksek Hızlı Tren (YHT) and Maglev lines in terms of their number of trips and generalized journey lengths in order to determine total societal costs. Additionally, the time spent in the vehicle and the penalties for service intervals are included into the overall trip time. At the moment, the Maglev system is working at capacity, and the change in service is anticipated to increase demand by 25%. (14.25 million Passengers in the first year). Infrastructure construction and maintenance costs are included in the total infrastructure costs, which are projected to be about \$ 20 billion in the first year using a capital recovery factor of 0.06 and a 5% societal discount rate. In terms of user costs, access/egress times by car were estimated to be 4 hours and 33 minutes, while in-vehicle travel time and waiting time were estimated to be 5 hours and 20 minutes. The Maglev line's annual societal cost is projected to be \$ 4.5 billion for 18.96 million passengers. As a consequence, the social cost per passenger is on average \$ 46. Comparable data for the high-speed train Yüksek Hızlı Tren (YHT) show a societal cost of \$ 25 per passenger at \$ 5.50 billion per year for 1 million passengers (10).

The Istanbul-Ankara Maglev system, as part of Turkey's future transportation initiatives, establishes a new intercity system and introduces new competition to the intercity transit market. On a long-term basis, the average societal cost of HSR is roughly 16 percent more than that of Maglev.

- The Istanbul-Ankara SC Maglev technology system creates a new intercity system and provides fresh competitiveness in the intercity transit market as part of Turkey's future transportation development.
- In comparison to the YHT expected demand of 11.4 million passengers, the anticipated SC Maglev system for the Istanbul-Ankara corridor saw a 25% increase in demand, culminating in the first year of service, 14.25 million passengers were carried.

- Total annual operating cost of infrastructure building and maintenance, as well as the purchase, operation, and maintenance of rolling stock, is \$ 27.1 billion, which is more than YHT's \$ 5.5 billion.
- Consumers pay a total of \$ 945 million per year as a consequence of access/egress timings, waiting time, and in-vehicle time, which is more than YHT's annual cost of \$ 855 million.
- SC Maglev train will decrease the use of electric power by 40% than YHT, which will cost about \$ 4 million incited of \$9.82 million per year.

#### **4.1 Returning of the Cost**

Based on an anticipated demand of 14.25 million passengers commuting between Istanbul and Ankara each year, the total societal cost of the SC Maglev line is \$ 27.1 billion, with a 10% annual increase in passengers using the line, using a capital recovery factor of 0.1 and a social discount rate of 35 years.

After 5 years the number of passengers using this line will be 18.96 million passenger every year, there is many factors will increase the number of passengers first, the trip will take less than hour, the population will increase to reach 90 million in 2030. In this case two scenarios can apply to returning the cost, first one if the ticket will cost \$ 46 for the passenger it will take about 35 years to return the cost, but when calculating the shipping profit the returning of the cost will reduce since if the train can carry 1,000 passenger in every trip with a ticket cost of 46\$ and with total trip profit of 46,000\$, while if charging 1\$ per 1 kg for shipping that can carry in one trip 80 tons the total profit of the trip will be 80,000\$ this will reduce the returning of the cost to 20 years taking into consideration that during the day there will be passengers trips and shipping trips.

The SC Maglev train can ship about 3521.88 tons every day and if there is 20 trips per day the returning of the cost will take less than 20 years with shipping in less time and cost the size of the market will increase and SC Maglev will be the main shipping line between Istanbul and Ankara, knowing that during 2030 Turkey will be one of the top 5 economics countries to be more than \$1 trillion.

## **4.2 Future Profits & Recommendation**

After returning the cost of the SC Maglev, the profits will be as follow:

According to the increasing number of the passenger's the number of passengers will be about 19 million per year, and if the ticket fees for the trip is \$ 46 per passenger it will give in return \$ 900 million, and the budget for maintenance for SC Maglev system should be \$ 228 million knowing that the total income is \$ 900 million so the profit will be \$ 672 million.

The \$ 672 million will invested to improve the power source of the system by building solar panels in the way of the SC Maglev over it, the solar panels will cover 60% of the needed power for the system, and part of the profit can be used to build new line from Ankara to Izmir which is the third biggest city in turkey and this line will play a big rule to increase the economics and connect the biggest cities in Turkey in a high speed transportation and shipping system.

Hyper loop is one of the fastest future technologies, according to the researches they are using the Maglev technology to run the train bet with covering the rail to reduce the air resistance to reach 1000 km/h, Istanbul - Ankara SC Maglev can be updated to be a Hyper loop system. In nowadays prices it will cost \$40 million per km, but the cost of this technology will reduce since are working to improve it.

## REFERENCES

- Allard RF, Moura F.** (2013). Analysis of Accessibility Distributions for Inter-city Travel by Public Transport.
- Athira I, Muneera C, Krishnamurthy K, Anjaneyulu M.** (2016). Estimation of Value of Travel Time for Work Trips. *Transportation Research Procedia*. 2016; 17:116-23. doi: 10.1016/j.trpro.
- Batley R, Mackie P, Wardman M.** (2013). Review of the value of time assumptions for business travellers on HS2. London: DfT.
- Boldea I, Tutelea LN, Xu W, Pucci M (2018)** Linear electric machines, drives, and MAGLEVs: an overview. *IEEE Trans Ind Electron*
- Cao R, Cheng M, Mi CC, Hua W** (2014). Influence of leading design parameters on the force performance of a complementary and modular linear flux-switching permanent-magnet motor. *IEEE Trans Ind Electron*
- Cao R, Cheng M, Mi CC, Hua W** (2014). Influence of leading design parameters on the force performance of a complementary and modular linear flux-switching permanent-magnet motor. *IEEE Trans Ind Electron* 61(5):2165–2175
- Castellanos, (2018)** Magnetic Levitation Control Based on Flux Density and Current Measurement. *Appl. Sci*, 8, 2545.
- Central Japan Railway Company (11 May 2010)*. Test Ride of Superconducting Maglev by the US Secretary of Transportation, Mr. Ray LaHood.
- Central Japan Railway Company* (2012). "The Chuo Shinkansen Using the Superconducting Maglev System"
- Central Japan Railway Company* (2012). "Central Japan Railway Company Annual Report 2012" (PDF). pp. 23–25. Retrieved 23 July 2013.
- Chin YK, Soulard J (2003)** A permanent magnet synchronous motor for traction applications of electric vehicles. In: *IEEE international conference on electric machines and drives conference, IEMDC 2003*, 1–4 June 2003, Madison, USA
- Çok Yüksek Hızlı Tren Setlerinin İkincisi Geldi.** (2016). *TCDD*.
- Daldaban F, Ustkoyuncu N** (2010). A Novel Linear Switched Reluctance Motor for Railway Transportation Systems. *Energy Convers Manag* 51:465–469.

- Ding, Z.; Li, W.; An, J.; Hao, L.; Zhang, Q.** (2016). Adaptive fuzzy fault-tolerant control with guaranteed tracking performance for nonlinear strict-feedback systems. *Fuzzy Sets Syst.*, 302, 82–100.
- El-Refaie AM** (2013). Motors/generators for traction/propulsion applications: a review. *IEEE Veh Technol*
- El-Refaie AM** (2013). Motors/generators for traction/propulsion applications: a review. *IEEE Veh Technol Mag* 8(1):90–99
- Filho AFF, Rinaldi V** (2006). The development of a linear switched reluctance motor with improved force profile. In: 3rd IET international conference on power electronics, machines and drives, PEMD 2006, 4–6 April 2006, Dublin, Ireland
- GDP - Composition by Sector** (2016). CIA World Factbook.
- General Electric**, (2016). Japan Rail and Mitsui all aboard high-speed rail proposal.
- Gerada D, Mebarki A, Brown NL, Gerada C, Cavagnino A, Boglietti A** (2014). High-speed electrical machines: technologies, trends, and developments. *IEEE Trans Ind Electron*
- Gutierrez, H.M.; Luijten, H.** (2018). 5-DOF Real-Time Control of Active Electrodynamic MAGLEV. *IEEE Trans. Ind. Electron.*
- Gwilliam KM.** (1997). The value of time in economic evaluation of transport projects: lessons from recent research. Washington: World Bank DC.
- Han HS, Kim DS** (2016). Magnetic levitation: Maglev technology and applications. Springer, Berlin
- Han, S.; Lee, J.** (2014). Recurrent fuzzy neural network backstepping control for the prescribed output tracking performance of nonlinear dynamic systems. *ISA Trans.*, 53, 33–43.
- Hasirci U, Balikci AK, Zabar Z, Birenbaum L** (2015). 3-D FEM analysis of a novel magnetic levitation system. *IEEE Trans Plasma Sci* 43(5):1261–126
- He, J.L.; Rote, D.M.; Coffey, H.T.** (1994). "Study of Japanese Electrodynamic-Suspension Maglev Systems". *NASA Sti/Recon Technical Report N.*
- Hellinger R, Mnich P** (2009). Linear motor-powered transportation: history, present status, and future outlook. *Proc IEEE*
- Holmer P** (2003) Faster than a speeding bullet train. *IEEE Spectrum*
- Jang SM, Park JH, You DJ, Cho HW, Sung HK** (2007). Design of high speed linear switched reluctance motor. In: International conference on electrical machines and systems, ICEMS 2007, 8–11 Oct 2007, Seoul, South Korea
- Japanese rail company** (2016). eyes exports to cover maglev costs. *Nikkei Asian Review.*

- Kakinoki T, Yamaguchi H, Murakami T, Mukai E, Nishi H** (2016). Development of linear switched reluctance motor for magnetically levitated system. In: 19th International conference on electrical machines and systems, ICEMS 2016, 13–16 Nov 2016, Chiba, Japan
- Kim,W.; Shin, D.; Chung, C.** (2012). The Lyapunov-based controller with a passive nonlinear observer to improve position tracking performance of micro stepping in permanent magnet stepper motors. *Automatica*
- Krishnan R** (2005). Propulsion with and without wheels. In: IEEE international conference on industrial technology, IEEE-ICIT 2005, 14–17 Dec 2005, Hong Kong, China
- Kurtenbach, Elaine** (14 January 2008). "Shanghai Residents Protest Maglev Train".
- Lee J, Jo J, Han Y, Lee C** (2013). Development of the linear synchronous motor propulsion testbed for super speed Maglev.
- Lee, H.W.; Kim, K.C.; Lee, J.** (2006). Review of Maglev Train Technologies. *IEEE Trans. Magn.*
- Lee, J.S.; Choi, S.; Kim, S.S. Park, C.; Kim, Y.G.** (2012). A Mixed Filtering Approach for Track Condition Monitoring Using Accelerometers on the Axle Box and Bogie. *IEEE Trans. Instrum. Meas.*
- Li X. A** (2015). Comparative Assessment for Innovative Public Transport Technologies: University of Southampton.
- Li, M.; Persson; Spännar, J. Berg, M.** (2012). On the use of second-order derivatives of track irregularity for assessing vertical track geometry quality. *Veh. Syst. Dyn.*, 50, 389–401.
- Lin, G.; Sheng, X.** (2018). Application and further development of Maglev transportation in China. *Transp. Syst. Technol.*, 4, 36–43.
- Long Z, He G, Xue S.** (2011). Study of EDS & EMS hybrid suspension system with permanent-magnet Halbach array. *IEEE Trans Magn*
- Maibach M.** (2008). Handbook on estimation of external costs in the transport sector. CE Delft.
- McCurry, Justin** (21 April 2015). "Japan's Maglev Train Breaks World Speed Record with 600 km/h Test Run".
- Meins J, Miller L, Mayer WJ** (1988).The high speed Maglev transportation system TRANSRAPID. *IEEE Trans Magn*
- Min, D.J.; Kwon, S.D.; Kwark, J.W.** (2017). Kim, M.Y. GustWind Effects on Stability and Ride Quality of Actively Controlled Maglev Guideway Systems. *Shock Vib.*, 35, 1–23.
- Otkun, SefaAkpınar A.** (2017). an experimental study on the effect of thrust force on motor performance in linear permanent magnet synchronous motors. *Electr Power Compon Syst*

- Park CB, Lee BS, Lee JH, Lee SK, Kim JH, Jung SM** (2013). Design of coreless-typed linear synchronous motor for 600 km/h very high speed train. In: International conference on electrical machines and systems, ICEMS 2013, 26–29 Oct 2013, Busan, South Korea
- Pellegrino G, Vagati A, Boazzo B, Guglielmi P** (2012). Comparison of induction and PM synchronous motor drives for EV application including design examples. *IEEE Trans*
- Pellegrino G, Vagati A, Boazzo B, Guglielmi P** (2012). Comparison of induction and PM synchronous motor drives for EV application including design examples. *IEEE Trans Ind Appl* 48(6):2322–2332
- Pfanner, Eric** (19 November 2013). Japan Pitches Its High-Speed Train With an Offer to Finance. *The New York Times*
- Powell J, Danby G** (2007). MAGLEV the new mode of transport for the 21st century. In: Schiller institute conference on the Eurasian land-bridge becomes a reality! 15–16 Sept 2007, Kiedrich, Germany
- Rail Delivery group**, (2018). passenger Demand Forecasting Handbook.
- Schultz L, Haas O, Verges P, Beyer C, Rohlig S, Olsen H, Kuhn L, Berger D, Noteboom U, Funk U** (2005). Superconductively levitated transport system: the SupraTrans project. *IEEE Trans Appl Supercond*
- Shi, J.; Fang, W.S.; Wang, Y.J.; Zhao, Y.** (2014). Measurements and analysis of track irregularities on high speed maglev lines. *J. Zhejiang Univ. Sci. A*, 15, 385–394.
- Small KA.** (2007). The Economics of Urban Transportation; doi: 10.4324/9780203642306
- Thornton R.D. (2009).** Efficient and affordable maglev opportunities in the United States. *Proc IEEE*
- U.S.-Japan Maglev** (2012). "History". *USJMAGLEV*. Retrieved 26 December 2014.
- Uzuka T.** (2011). Trends in high-speed railways and the implications on power electronics and power devices. In: *IEEE 23<sup>rd</sup> international symposium on power semiconductor devices and ICs, ISPSD 2011*, 23–26 May 2011, San Diego, CA
- Uzuka T.** (2013). faster than a speeding bullet: an overview of Japanese high-speed rail technology and electrification. *IEEE Electrif*
- Vansteenwegen P, Van Oudheusden D.** (2006). Decreasing the Passenger Waiting Time for an Intercity Rail Network. *Transportation Research Part B: Methodological*. 2007; 41(4):478-92. doi: 10.1016/j.trb.
- Velaro Turkey: High-Speed Train for TCDD** (2020). Siemens Mobility.
- Wang D, Wang X, Du XF** (2017). Design and comparison of a high force density dual-side linear switched reluctance motor for long rail propulsion application with low cost. *IEEE Trans Magn* 53(6):1–4



**Wang DH, Shao CL, Wang XH, Chen XJ** (2016). Design and performance comparison of a bilateral yokeless linear switched reluctance machine for urban rail transit system. In: IEEE conference on vehicle power and propulsion, VPPC 2016, 17-20 October 2016, Hangzhou, China

**Yao, J.; Jiao, Z.; Ma, D.; Yan, L.** (2014). High-Accuracy Tracking Control of Hydraulic Rotary Actuators with Modeling Uncertainties. IEEE/ASME Trans. Mechatron., 19, 633–641.

## Internet

**García-Amoro's J, Andrada P, Blanque' B.** (2015). Assessment of linear switched reluctance motor's design parameters for optimal performance. Electr Power Compon Syst 43(7):810–819. <https://doi.org/10.1080/15325008.2014.1004001>

**Garcia-Amoro's J, Andrada P, Blanque' B.** (2011). Design procedure for a longitudinal flux flat linear switched reluctance motor. Electr Power Compon Syst 40(2):161–178. <https://doi.org/10.1080/15325008.2011.629333>

**Kuntz S, Burke PE, Slemon GR.** (1978). Active damping of maglev vehicles using superconducting linear synchronous motors. Electr Mach Power Syst 2(4):371–384. <https://doi.org/10.1080/03616967808955318>

**Monjo L, Sainz L.** (2015). Study of resonances in 19.25 kV AC traction systems. Electr Power Compon Syst. <https://doi.org/10.1080/15325008.2015.1048908>

**Otkun O, SefaAkpınar A.** (2017). An experimental study on the effect of thrust force on motor performance in linear permanent magnet synchronous motors. Electr Power Compon Syst45(18):20172024. <https://doi.org/10.1080/15325008.2017.1380730>

**Passenger Department** (2018). High speed rail fast track to sustainable mobility. International Union of Railways (UIC). [https://uic.org/IMG/pdf/uic\\_high\\_speed\\_2018\\_ph08\\_web.pdf](https://uic.org/IMG/pdf/uic_high_speed_2018_ph08_web.pdf)

**Passenger Department** (2018). Passenger activities at UIC. International Union of Railways (UIC). [https://uic.org/IMG/pdf/brochure\\_passagers.pdf](https://uic.org/IMG/pdf/brochure_passagers.pdf)

**Rivera NN.** (2007). Permanent Magnet DC traction motor with reconfigurable winding control. Transportation Research Board of the National Academies. [http://onlinepubs.trb.org/onlinepubs/archive/studies/idea/finalreports/highspeedrail/hsr-44final\\_report.pdf](http://onlinepubs.trb.org/onlinepubs/archive/studies/idea/finalreports/highspeedrail/hsr-44final_report.pdf)

**Shanghai Maglev Transportation Development Co. Ltd.** (2005). Maglevtechnology. <http://www.smtdc.com/en/gycf3.html>.

**Shieh NC, Tung PC.** (2002). Robust position regulation control of a transportation carriage directly driven by linear brushless DC motor. Electr Power Compon. <https://doi.org/10.1080/15325000290085091>

**World Economic Outlook** (2020). [www.imf.org](http://www.imf.org).

## RESUME

### EDUCATION

**Master of Science - Engineering Management**  
Istanbul Gedik University

10/2019 to present

Istanbul, Turkey

**B.S. in Electrical Engineering**  
Lebanese International University

09/2015 to 06/2019

Beirut, Lebanon

### TRAINING & CERTIFICATIONS

**Digital marketing** (05/20)

Udemy

**Marketing Hackathon I** (03/16)

JCI Beirut

**Marketing Hackathon II** (04/17)

JCI Beirut

**Cybersecurity Specialist** (05/16)

Cisco

**LabVIEW software** (05/16)

LabVIEW

**LabVIEW My Rio** (05/16)

LabVIEW

### AWARDS & ACHIEVEMENTS

**Winning the 3rd place** (03/18)

Agri-food tech

**2nd best Engineering project**

LIU Engineering Exhibition

**TURKSAT Satellite Competition** (10/19)

TURKSAT

### VOLUNTEER & PERSONAL PROJECTS

**Volunteer @ Institute of Electrical  
and Electronics Engineers** (2017-present)

**Engineering Student Branch President**

Lebanese International University (2018-2019)

**Organizing engineering exhibition**

Lebanese International University (07/18)

**Organizing GRAND TECH 18**

Lebanese International University (04/18)

**Organizing Student & young Professional Lebanon congress**

Lebanese International University (07/18)